

# **Exhibit B**

# **MONTANA-DAKOTA UTILITIES CO.**

## **Guidelines for Interconnection Requirements and Parallel Operation of Customer Owned Generation**

**September 26, 2007**

MONTANA-DAKOTA UTILITIES CO.  
GUIDELINE FOR INTERCONNECTION REQUIREMENTS AND PARALLEL  
OPERATION OF CUSTOMER-OWNED GENERATION  
SEPTEMBER 26, 2007

Supersedes previous Guideline dated January 1999

INDEX

<u>I. INTRODUCTION</u>	page 1
<u>II. APPLICATION FOR INTERCONNECTION</u>	page 3
<u>III. INTERCONNECTION STUDIES</u>	page 4
<u>IV. INTERCONNECTION REQUIREMENTS</u>	page 4
A. Operating Limits	page 4
1. Voltage	page 4
2. Flicker	page 5
3. Load Transfer	page 6
4. Frequency	page 6
5. Power Factor	page 6
6. Harmonics	page 7
B. Transformer	page 8
C. Energization of Company Equipment by Customer	page 9
D. Synchronization of Customer Generation	page 9
E. Disconnect	page 9
F. Metering	page 9
G. Grounding	page 10
H. Interruptible Rate Qualification	page 10

<u>V. CLASSIFICATION OF INSTALLATIONS</u>	page 10
<u>VI. PROTECTIVE DEVICES</u>	page 11
A. Circuit Breakers	page 11
B. Closed Transition Transfer Switches	page 12
C. Relays	page 12
1. Overcurrent relays	page 13
2. Overvoltage relays	page 13
3. Undervoltage relays	page 13
4. Negative sequence overvoltage relays	page 13
5. Overfrequency relays	page 14
6. Underfrequency relays	page 14
7. Reverse power relays	page 14
8. A parallel limit timing relay	page 14
9. A zero sequence inverse time overvoltage detection relay scheme	page 14
10. For generators connected directly to Company's system without an interconnection transformer	page 15
11. For generator installations having generators not limited to 180 seconds parallel operation time	page 15
12. For generator installations where power may flow to and from Customer	page 15
13. For medium or large generator installations which will operate in parallel with Company's system beyond 180 seconds	page 15
14. Relaying modifications may be necessary	page 15
15. All changes in relays or relay settings desired by Customer	page 16
16. All relays shall meet the following tolerances	page 16

D. Single-Phase Devices - Fuses/Oil Circuit Reclosers	page 16
E. Automatic Reclosing/Voltage Check Schemes	page 16
F. Communication Channel	page 17
G. Control Batteries	page 17
<u>VII. TESTING REQUIRED FOR PARALLEL OPERATION</u>	page 17
A. Initial Pre-qualifying Testing	page 18
B. Open Transition Operation and Testing	page 19
C. Closed Transition Testing	page 19
D. Parallel Operation	page 20
E. Re-Qualification Testing	page 20
F. Electric Service Interruptions During Testing	page 21
<u>VIII. OPERATING GUIDELINES</u>	page 21
<u>IX. FUTURE CHANGES</u>	page 22

## APPENDIX

Appendix "A"  
(One-Line Diagrams)

Appendix "B"  
(Interconnection Equipment and Generator Data Information Form)

Appendix "C"  
(Application for Interconnection of Customer-Owned Generation)

MONTANA-DAKOTA UTILITIES CO.  
GUIDELINE FOR INTERCONNECTION REQUIREMENTS AND PARALLEL  
OPERATION OF CUSTOMER-OWNED GENERATION  
SEPTEMBER 26, 2007

Supersedes previous Guideline dated January 1999

INDEX

<u>I. INTRODUCTION</u>	page 1
<u>II. APPLICATION FOR INTERCONNECTION</u>	page 3
<u>III. INTERCONNECTION STUDIES</u>	page 4
<u>IV. INTERCONNECTION REQUIREMENTS</u>	page 4
A. Operating Limits	page 4
1. Voltage	page 4
2. Flicker	page 5
3. Load Transfer	page 6
4. Frequency	page 6
5. Power Factor	page 6
6. Harmonics	page 7
B. Transformer	page 8
C. Energization of Company Equipment by Customer	page 9
D. Synchronization of Customer Generation	page 9
E. Disconnect	page 9
F. Metering	page 9
G. Grounding	page 10
H. Interruptible Rate Qualification	page 10

<u>V. CLASSIFICATION OF INSTALLATIONS</u>	page 10
<u>VI. PROTECTIVE DEVICES</u>	page 11
A. Circuit Breakers	page 11
B. Closed Transition Transfer Switches	page 12
C. Relays	page 12
1. Overcurrent relays	page 13
2. Overvoltage relays	page 13
3. Undervoltage relays	page 13
4. Negative sequence overvoltage relays	page 13
5. Overfrequency relays	page 14
6. Underfrequency relays	page 14
7. Reverse power relays	page 14
8. A parallel limit timing relay	page 14
9. A zero sequence inverse time overvoltage detection relay scheme	page 14
10. For generators connected directly to Company's system without an interconnection transformer	page 15
11. For generator installations having generators not limited to 180 seconds parallel operation time	page 15
12. For generator installations where power may flow to and from Customer	page 15
13. For medium or large generator installations which will operate in parallel with Company's system beyond 180 seconds	page 15
14. Relaying modifications may be necessary	page 15
15. All changes in relays or relay settings desired by Customer	page 16

16. All relays shall meet the following tolerances	page 16
D. Single-Phase Devices - Fuses/Oil Circuit Reclosers	page 16
E. Automatic Reclosing/Voltage Check Schemes	page 16
F. Communication Channel	page 17
G. Control Batteries	page 17
<b><u>VII. TESTING REQUIRED FOR PARALLEL OPERATION</u></b>	page 17
A. Initial Pre-qualifying Testing	page 18
B. Open Transition Operation and Testing	page 19
C. Closed Transition Testing	page 19
D. Parallel Operation	page 20
E. Re-Qualification Testing	page 20
F. Electric Service Interruptions During Testing	page 21
<b><u>VIII. OPERATING GUIDELINES</u></b>	page 21
<b><u>IX. FUTURE CHANGES</u></b>	page 22

## APPENDIX

Appendix "A"  
(One-Line Diagrams)

Appendix "B"  
(Interconnection Equipment and Generator Data Information Form)

Appendix "C"  
(Application for Interconnection of Customer-Owned Generation)



MONTANA-DAKOTA UTILITIES CO.

GUIDELINE FOR INTERCONNECTION REQUIREMENTS AND PARALLEL  
OPERATION OF CUSTOMER-OWNED GENERATION  
SEPTEMBER 26, 2007

Supersedes previous Guideline dated January 1999

I. INTRODUCTION

This guideline developed by Montana-Dakota Utilities Co. (Company) is to serve as a reference for establishing the Company/Customer interconnection for a Customer having generation which is operated in parallel with Company's system. "Generation" is defined as any device producing electrical energy, i.e., rotating generators driven by steam turbines, internal combustion engines, hydraulic turbines, windmills, etc.; photo voltaic or battery arrays with a DC to AC inverter; or any other electric generating device.

This document defines the minimum requirements for the safe and effective implementation of such an interconnection. System interconnection and operating requirements for such installations will be determined separately for each installation as they are dependent upon location, generator size and other system parameters.

The requirements stated in this guideline are intended to achieve the following:

- Insure the safety of the general public and Company personnel.
- Minimize the possible damage to the property of the general public, Company and Customer.
- Minimize adverse operating conditions on the Company's system.

In order to achieve these goals, certain protective devices (relays, circuit breakers, etc.) must be installed to promptly disconnect Customer's generation from the Company's system whenever a fault or abnormality occurs. The determination of what types of protective devices are required depends primarily on three factors:

1. The type and size of Customer's generating equipment.
2. The location of Customer on Company's system.
3. The manner in which the installation will operate.

In addition to the protective devices, certain modifications and/or additions may be required to Company's system due to the addition of Customer's generation. Each request will be handled individually, and the final determination of the protective devices, modifications, and/or additions required will be made by Company. Company will work with Customer to achieve an installation which meets the requirements of both parties.

Company requires reimbursement of all costs incurred by Company for system additions or changes that are required to permit parallel operation of the Customer's generation with Company's system by Customer.

Company assumes no responsibility for protection of the Customer's generating equipment or of any other portion of the Customer's electrical system. Customer is solely responsible for protecting Customer's equipment in such a manner that faults, imbalances, or other disturbances on Company's system do not cause damage to the Customer's equipment.

Customer shall be responsible for complying with all applicable local, state and federal electrical and safety codes, and standards.

It is also recommended that Customer's equipment and installation comply with latest revision of the ANSI/IEEE standards applicable to Customer's installation. The following are some of the guides and standards that apply to the generator installations covered by this guideline.

"National Electrical Safety Code", ANSI C2-1997, Published by The Institute of Electrical and Electronics Engineers, Inc.

"IEEE Standard Relays and Relay Systems Associated with Electric Power Apparatus", ANSI/IEEE C37.90, 1989.

"Guide for Protective Relaying of Utility-Consumer Interconnection", ANSI/IEEE C37.95, 1989.

"IEEE Guide for Safety in AC Substation Grounding", ANSI/IEEE Std. 80- 1986.

"IEEE Standard for Interconnecting Distributed Resources with Electric Power Systems ", IEEE Std. 1547, 2003

"Reliability Consideration for Integrating Non-Utility Generating Facilities with the Bulk Electric Systems", North American Electric Reliability Council, Princeton, NJ 08540, April 1987.

Recommended Practice for Protection and Coordination of Industrial and Commercial Power Systems - "Buff Book", ANSI/IEEE Std. 242-1986.

Recommended Practice for Emergency and Standby Power Systems for Industrial and Commercial Application - "Orange Book", ANSI/IEEE Std. 446-1995.

The National Electrical Code, National Fire Protection Association, Quincy, MA, 02269, 1999 Edition.

"IEEE Guide for Interconnection of User-Owned Substations to Electric Utilities". IEEE Std. 1109-1990

"IEEE Recommended Practices and Requirements for Harmonic Control in electrical Power Systems". IEEE Std. 519-1992

## II. APPLICATION FOR INTERCONNECTION

In order to process all interconnection requests in an efficient and consistent manner, Customer should follow the procedures outlined below.

A. Customer should submit the following to Company:

1. A completed "Application for Interconnection of Customer-Owned Generation" form. (Appendix "C")
2. A preliminary one-line electrical diagram, which provides as much detail as available on the proposed generating equipment and facility.
3. For a "Qualifying Facility" under the Public Utilities Regulatory Policies Act (PURPA), certification that the cogeneration or small power production facility meets the criteria as defined in Title 18, code of Federal Regulations (CFR), Section 292.201 through 292.207.

The completed application and one-line diagram will be used by Company to perform a "Preliminary Interconnection Study". During this interconnection study, additional details of the proposed facility may be required and will be requested from Customer as needed.

It should be noted that this "Preliminary Interconnection Study" will normally take a minimum of six weeks to complete. The application should therefore be submitted as early as possible.

B. Upon completion of the "Preliminary Interconnection Study", Company will provide the following to Customer:

1. A determination of whether the proposed interconnection will be classified as parallel or non-parallel operation of Customer-owned generation with Company's system.
2. Details of any modifications required to Company's system and/or Customer's proposed configuration for an acceptable interconnection.
3. A preliminary estimate of costs to Customer and a preliminary construction schedule for any necessary modifications to Company's system if required.

C. If Customer decides to proceed with installation of the proposed interconnection, Customer must provide Company the following:

1. A detailed one-line diagram of the proposed facility.
2. All applicable elementary diagrams.
3. Available interconnection equipment and generator data in accordance with Appendix "B" attached.
4. All other appropriate drawings or documents necessary for the proper design of the interconnection and proper coordination of Customer's generation with Company's system.

After the above required information has been submitted to Company, an "Interconnection Study" will be performed and an agreement will be developed by Company. The "Interconnection Study" and development of the agreement will usually take a minimum of six weeks (excluding final engineering, construction, equipment purchase and delivery, etc.). Customer is therefore requested to provide the above requested items as soon as practical after receipt of Company's response set forth in paragraph B above. The agreement will include design requirements, details of the customer contribution to the cost of any modifications required to Company's system, operational and maintenance requirements and a tentative schedule for any work to be performed.

- D. Customer shall inform Company of any changes in design or scheduling which may occur. Design changes which may affect the interconnection must be reviewed by company and approved in writing.
- E. Prior to energizing Customer's interconnection and generating equipment, Company reserves the right to inspect the installation to assure it meets the requirements set forth in the agreement.

### III. INTERCONNECTION STUDIES

Company will perform, at no cost to the customer, the interconnection studies to determine what additions and/or modifications may be required to Company's system and Customer's proposed interconnection plans. An interconnection study will address several items such as: protective relaying requirements, interconnection equipment ownership, equipment upgrade requirements, right-of-way requirements, and other factors introduced by the proposed generation to the system voltage e.g. regulation, harmonics, ampacity, increase in short circuit currents, system stability, line losses, other customer owned generation in the area, etc.

### IV. INTERCONNECTION REQUIREMENTS

The following requirements apply to all generating equipment operated in parallel with Company's system. This applies to all three-phase and single-phase generators or inverter installations, as appropriate. Company's system shall be the source side and Customer's system shall be the load side in the following interconnection requirements.

#### A. Operating Limits

In order to minimize objectionable and adverse operating conditions on the electric service provided to other customers on Company's system, Customer's generation shall meet the following operating criteria:

##### 1. Voltage

Customer's generating equipment shall not cause excessive voltage excursions. Customer shall operate generation at a level of plus/minus 6.0% of the nominal voltage level at the interconnection point. Customer shall provide an automatic means of disconnecting Customer's generating equipment from the Company's system within one second if the voltage cannot be maintained within the plus/minus 6.0% tolerance.

Installations which are allowed extended parallel operation may be required to operate according to a voltage schedule specified by Company within the plus/minus 6.0% voltage limit and the reactive capability of the generating equipment.

2. Flicker

For installations 12.5kV and below, Customer shall not cause voltage flicker in excess of 2%, except, frequently recurring voltage flicker shall not be in excess of the curve shown below at the indicated intervals, (fig. 1). Measurements for voltage flicker are to be made at the high voltage side of a dedicated transformer if one is present, or at the point of interconnection if no dedicated transformer is present.

For installations above 12.5kV, Customer shall not cause voltage flicker in excess of 1%, except, frequently recurring voltage flicker shall not be in excess of 50% of the curve values shown below at the indicated intervals, (fig. 1). Measurements for voltage flicker are to be made at the high voltage side of a dedicated transformer if one is present, or at the point of interconnection if no dedicated transformer is present.

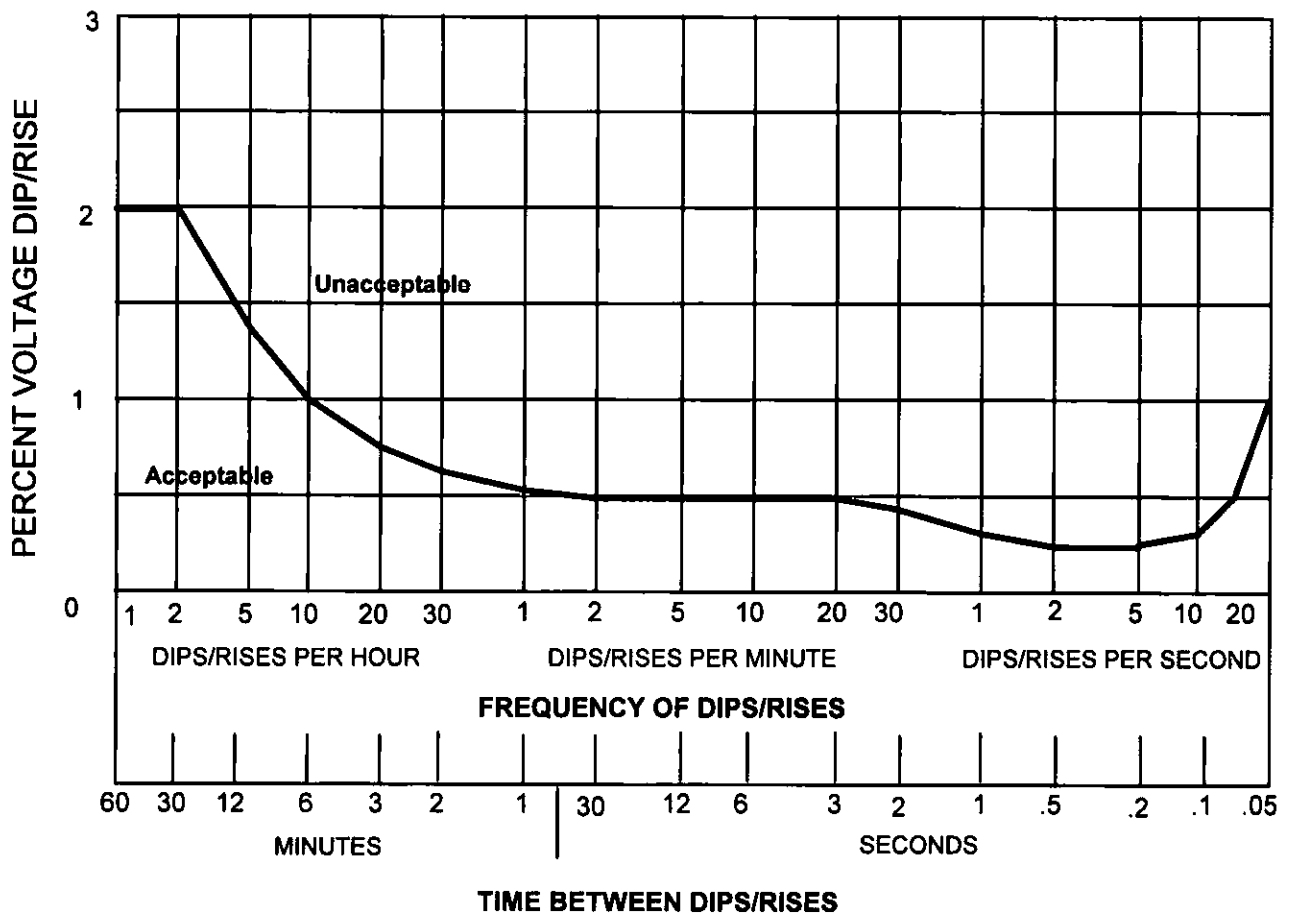

Figure 1

### 3. Load Transfer

"Block" load transfer is when Customer's load is transferred from Company or to Company as a single unit without provision for a gradual decrease or increase of the amount carried by Company.

"Soft" load transfer is when Customer's load is transferred from Company or to Company by gradually decreasing or gradually increasing the amount carried by Company over a period of time. "Ramp rate" is a specific amount of load that can be transferred over a specific amount of time. "Maximum ramp rate" is the maximum amount that can be transferred over a specified amount of time. The "ramp" may either be a continuously smooth transition or may be a series of small incremental "blocks".

If Customer's peak load when transferred as a "block" will result in voltage fluctuation in excess of that specified under "Flicker" above, or if Customer's load to be transferred exceeds 1000kW, then a "soft" transfer of the load will be required. If a "soft" transfer of load is required, both a "maximum block" and a "maximum ramp rate" will be specified in the interconnection studies. Transfer of the last incremental block of load shall be controlled so that the final block of load transferred is less than the maximum block allowed. If extended ramp times are required for large generator installations intended for only limited parallel operation, the allowed limited parallel operation time will be increased beyond 180 seconds for that specific case.

### 4. Frequency

System frequency during parallel operation is determined by the Company's interconnected system.

Customer installations designed for limited parallel operation shall not deviate more than one-half of a hertz from a 60 hertz base. Customer shall provide an automatic method of disconnecting Customer's generating equipment from Company's system within 0.2 second if the frequency can not be maintained within this tolerance.

Customer installations designed for extended parallel operation shall remain connected to Company's system as long as Customer's generation can contribute to restoration of the frequency to 60 hertz. Depending upon the type and size of equipment installed, Company reserves the right (within industry standards) to specify governor response and frequency-load conditions for disconnecting from Company's system.

### 5. Power Factor

When operating in parallel with Company's system, Customer installations designed for limited parallel operation shall maintain a power factor with the range of 0.90 leading to 0.90 lagging.

Installations designed for extended parallel operation and not required to maintain a specified voltage schedule shall maintain a power factor with the range of 0.95 leading to 0.95 lagging.

Power factor requirements are unrestricted for generators operated by Customers required to maintain a specified voltage schedule.

## 6. Harmonics

The customer's generating equipment shall not introduce excessive distortion to Company's system voltage and current wave forms. The harmonic distortion measurements shall be made at the point of interconnection between Customer and Company systems and shall be within the limits specified in the tables below. These values are based upon IEEE Std. 519.

## a. Current harmonic distortion limits:

-----

**MAXIMUM ALLOWABLE HARMONIC CONTENT (CURRENT)**  
(for voltage levels up to 69kV)  
(In percent of total current)

	Harmonic Order Number (h)				
	$h < 11$	$11 \leq h < 17$	$17 \leq h < 23$	$23 \leq h < 35$	$35 \leq h$
ODD	4.0	2.0	1.5	0.6	0.3
EVEN	1.0	0.5	0.38	0.15	0.08

Total current harmonic distortion may not exceed 5.0%.

Current distortions that result in a dc offset, e.g.,  
half-wave converters, are not allowed.

-----

**MAXIMUM ALLOWABLE HARMONIC CONTENT (CURRENT)**  
(for voltage levels from 69kV up to 161kV)  
(In percent of total current)

	Harmonic Order Number (h)				
	$h < 11$	$11 \leq h < 17$	$17 \leq h < 23$	$23 \leq h < 35$	$35 \leq h$
ODD	2.0	1.0	0.75	0.3	0.15
EVEN	0.5	0.25	0.187	0.07	0.037

Total current harmonic distortion may not exceed 2.5%.

Current distortions that result in a dc offset, e.g.,  
half-wave converters, are not allowed.

-----

## b. Voltage harmonic distortion limit:

---

**MAXIMUM ALLOWABLE HARMONIC CONTENT (VOLTAGE)**  
(for voltage levels up to 69kV)

Maximum Individual Harmonic:	3.0%
Maximum Total Harmonic Distortion:	5.0%

---

**MAXIMUM ALLOWABLE HARMONIC CONTENT (VOLTAGE)**  
(for voltage levels from 69kV up to 161kV)

Maximum Individual Harmonic:	1.5%
Maximum Total Harmonic Distortion:	2.5%

---

**B. Transformer**

For parallel operation, the interconnection transformer requirements will vary from location to location, and will be determined by the interconnection studies. Specific transformer requirements will depend upon Company's system voltage and grounding requirements, Customer system voltage and grounding requirements, and duration of parallel operation.

Typical three-phase transformer requirements for interconnection with Company's 4.16kV or 12.5kV distribution system for parallel operation is a two winding transformer with a grounded-wye high side and grounded-wye low side connection. A transformer with an ungrounded wye or a delta connection on the source side will not be allowed at these voltage levels.

For interconnection with Company's system at higher voltages, a delta connected transformer on the transformer's high voltage side may be allowed in some cases if a zero sequence overvoltage detection scheme with relays is installed and coordinated with other protective devices. It may also be possible to install a grounding transformer at locations having a delta connected interconnection transformer when solid grounding is required. These items would be determined by the interconnection studies.

For interconnection with Company's system at any voltage, if the required transformer connection is grounded-wye on the transformer's high voltage side and delta on the transformer's low voltage side, or if a grounding transformer is installed on the high voltage side, a special highly-sensitive ground fault detection relay in conjunction with permissive transfer tripping between Company's substation and the interconnection location may be required. This is due to deterioration of the ability to detect ground faults. And/or, it may be required to install additional circuit breakers around the point-of-interconnection to provide adequate system fault protection. These items would be determined by the interconnection studies.

Auto-transformers with or without a delta tertiary winding will not be allowed as generator step-up transformers.



**C. Energization of Company Equipment by Customer**

1. Customer shall not energize a de-energized Company circuit. The necessary control devices shall be installed by Customer on Customer's equipment to prevent the energization of a de-energized Company circuit through the interconnection by Customer's generation.
2. A lockable switch shall be installed to disable all automatic and manual closing of the intertie breaker. This switch shall be accessible to and operated by Company personnel to obtain the necessary safety requirements when Company crews are working on energized equipment or lines serving Customer. This switch shall be locked in the "Closing Disabled" position, and the key will be removed by Company personnel when the work required so dictates. Once the work is completed, the key will be returned and the switch unlocked and placed in the "Closing Permitted" position.

**D. Synchronization of Customer Generation**

An automatic synchronizer is required for generators that must be synchronized to the electric system before connection. Customer shall be solely responsible for properly synchronizing Customer's generator with Company's system.

To prevent unnecessary voltage fluctuations on Company's system, Company requires that the synchronizing equipment be capable of closing the generator into Company's system within the following limits: Breaker closing angle of plus/minus 10 electrical degrees; voltage matching of 0 to +5% and frequency difference less than 0.067 hertz.

**E. Disconnect**

A disconnect device shall be installed to electrically isolate Company's system from the Customer's generation. This device shall provide a visible air gap between Customer's generating equipment and Company's system in order to establish the safety requirements for maintenance and repair work on Company's system. This disconnect device shall be readily accessible to and allow padlocking by Company personnel. This disconnect shall be designed to allow the application of safety grounds on the source side of the disconnect.

**F. Metering**

Modifications to the revenue metering are usually required to accommodate the installation of Customer generation. The exact requirements will be specified in the interconnection studies.

Customer installations designated as medium or larger and designed for extended parallel operation shall include watt, var and voltage transducers to meter the output of the generator(s), and also at the point-of-interconnection. The output of these transducers will be used for remote metering (telemetry) by Company's electric system dispatchers for the purpose of monitoring generation and load transfers. Transducers shall have a 1.0 milliamp DC current output wired to terminal board points in Customer's control equipment for connection to Company's equipment. The transducer type is subject to approval by Company.

## G. Grounding

A ground grid shall be installed of sufficient size to handle the maximum available ground fault current and shall be designed to limit step and touch potentials to safe levels as set forth in "IEEE Guide for Safety in AC Substation Grounding", ANSI/IEEE Std. 80-1986, or latest revision thereof.

All electrical equipment shall be grounded in accordance with local, state and federal electrical and safety codes and applicable standards.

## H. Interruptible Rate Qualification

Customer generation qualifying for an interruptible rate shall include provisions for a remote "Load Transfer" contact from Company in Customer's control equipment. This contact shall operate other automatic devices as required to start and cause the generator to come on line. Customer may also use this contact to alert Customer that an interrupt signal has been received.

For installations which are allowed only limited parallel operation, once an interrupt signal has been received and the load removed from Company, the load shall be prevented from re-transfer to Company until the interrupt contact is opened by Company even if Customer's generator should fail. A "52a" auxiliary switch from the interconnection circuit breaker is required to provide breaker position indication information to Company. If a closed transition transfer switch is used to transfer Customer load to and from Company, two "A" auxiliary switches (one following source side and one following generator side), are required to provide switch position indication information to Company. The auxiliary switch(s) should be wired to independent terminal board points in Customer's control equipment for connection to Company's equipment. These switches are to provide breaker/switch position information to Company's electric dispatcher in Bismarck, ND

## V. CLASSIFICATION OF INSTALLATIONS WITH CUSTOMER GENERATION

The following guidelines are used to determine the classification of Customer's generation (the sum of all sources of generation at one location), and are based upon criteria found in IEEE Std 242-1986:

1. Extremely Small - Generation of 100kVA maximum up to 600V.
2. Small Generator - From extremely small machine sizes up to 1000kVA maximum and up to 600V, 500kVA maximum above 600V.
3. Medium Generator - From small machine sizes up to 12,500kVA regardless of voltage.
4. Large Generator - From medium machine sizes up to approximately 50,000kVA.

In general, an increased degree of protection is required for each increase in generator size. This is due to the greater magnitudes of short circuit currents from these installations. The medium and large installations therefore require more sensitive and faster protection schemes to minimize damage and insure safety. A second consideration for medium and large generation installations is the possibility that a portion of Company's system may become "islanded". Islanding is an undesirable situation where a portion of Company's system, which includes Customer having generation and possibly other Company customers, becomes disconnected from the rest of Company's system but continues to operate as an isolated power system. This condition causes operating and safety problems and will be permitted only on medium and large generator installations.

The figures which follow in Appendix "A" show typical installations for the various combinations of generation size, interconnection location, and manner of operation. It must be emphasized that these are typical installations only and final installations may vary from the examples shown due to transformer connections, breaker configuration, etc. The specific protective device requirements will be established during the interconnection studies.

## VI. PROTECTIVE DEVICES

Various protective devices are required to permit the safe and proper operation of Company/Customer interconnection. Determination of the protective device requirements will be made by Company during the interconnection studies. It is Company's policy that Customer purchase, install and maintain this equipment as approved and specified by Company. Protective devices owned by Customer shall be maintained, inspected and tested based upon manufacturer recommendations and industry standards. Maintenance, inspection and testing shall be performed by Customer with Company maintaining the right to review all work performed.

### A. Circuit Breakers

Customer's facility shall include a utility intertie circuit breaker that is properly rated for the application. This circuit breaker shall be rated for voltage, continuous current and be capable of interrupting the maximum available short circuit current in accordance with the latest applicable ANSI/IEEE and NEMA standards. The utility intertie circuit breaker shall be tripped by all protective devices required herein. Circuit breakers are required for all installations where parallel operation is allowed. This includes all momentary parallel operation.

All utility intertie circuit breakers should be visually inspected at least once per week for any obvious signs of damage or inoperability. Any indication of circuit breaker inoperability shall be reported to Company immediately and shall require temporary suspension of any parallel operation until the appropriate inspections, tests and repairs have been completed.

## B. Closed Transition Transfer Switches

Closed transition transfer switches that are properly rated for the application may be utilized to transfer Customer load from Company to Customer generator and from Customer generator to Company in a make-before-break mode if both sources are within acceptable parameters of voltage and frequency. Upon loss of Company source, transfer switch shall operate in an open transition transfer mode if/when Customer load is transferred to Customer generator. Transfer switch controls shall prevent Customer generator from energizing a de-energized Company line. A utility intertie circuit breaker is still required when a closed transition transfer switch is used. The utility intertie circuit breaker shall be tripped by all protective devices required herein, but may otherwise remain closed under normal conditions allowing the transfer switch to transfer load between Company and Customer generator.

Transfer time of a high speed transfer switch is typically 100mS or less. This rate is acceptable where "block" load transfer is allowed. At locations where "soft" load transfer is required, the transfer switch parallel operation time must be adjustable and be increased as required to accommodate the load transfer ramp rate specified. With limited parallel operation and when soft load transfer is required, transfer of the last incremental block of load shall be controlled so that the final block of load transferred is less than the maximum block allowed.

A closed transition transfer switch may be applied with a bypass-isolation switch. The bypass-isolation switch must be designed to prevent closed transition switching while the bypass switch is in a bypass position. The bypass switch design should allow Customer load to be supplied from either Company source or from Customer generator.

The use of a closed transition transfer switch allows for periodic maintenance and testing of the utility intertie circuit breaker (maintenance and testing are required) without having to interrupt load. The use of a bypass-isolation switch with a closed transition transfer switch allows for periodic maintenance of the closed transition transfer switch (maintenance is required) without having to interrupt load.

## C. Relays

Protective relays are required to promptly sense abnormal operating or fault conditions and initiate the isolation of the faulted area. Relays with consistently precise and adjustable pickup levels and operating characteristics will be necessary to meet the minimum requirements herein.

Protective relays can be categorized into two major groups, "Industrial Grade" and "Utility Grade". Utility Grade relays have a higher degree of reliability and accuracy. A Utility Grade relay will be defined as a relay that can be removed from service by means of test plugs, test switches, or by removing the relay from its permanently mounted and wired case for the purpose of testing. The means provided for removing the relay must first disconnect the contact output functions of the relay before disconnecting AC potential, disconnecting DC power, and/or short circuiting before disconnecting of AC current. Multi-function type relays that combine individual functions are acceptable. Multi-function micro-processor based relays are acceptable and preferred, but the installation shall include externally wired knife style test switches for all inputs and outputs and must include provision for short circuiting before disconnecting of AC current. Utility Grade relays shall also meet or exceed ANSI/IEEE Standards for protective relays (i.e. C37.90, C37.90.1 and C37.90.2).

Utility Grade relays are required for intertie protection, except where specifically noted. This includes relays required by Company on generator installations for primary and/or backup protection of Company's system. See Appendix "A" for typical relaying function requirements for various combinations of generation size, interconnection location, and manner of operation. These are typical protective device requirements only and specific protective device requirements will be established for each interconnection during the interconnection studies. Use of Company approved Industrial Grade relays may be permitted on generation installations classified as extremely small.

Relays shall be equipped with setting limit ranges and other requirements as specified below. These setting limit ranges are not to be confused with the actual relay settings required for the proper operation of the installation.

1. Overcurrent relays shall monitor all three phases and neutral. These relays shall trip and lock-out the utility intertie circuit breaker for any fault condition. Automatic closing of the utility intertie circuit breaker shall not be permitted following trips initiated by the overcurrent relays until the lock-out device has been manually reset. Time delayed tripping will be permitted for those conditions where proper coordination can be achieved with Company's overcurrent protective equipment on its system. Instantaneous tripping will be required for all other conditions. In no case shall instantaneous tripping be set greater than 12 times the minimum pick-up setting of the overcurrent relay. Utility Grade relays will be required for utility intertie circuit breakers rated above 600 volts. Industrial Grade relays may be permitted for utility intertie circuit breakers rated 600 volts and under but testing of these relays will be required.
2. Overvoltage relays shall operate to trip the utility intertie circuit breaker at no greater than 110 percent of the nominal voltage level (132 volts on a 120 volt base) with a maximum time delay of 1.0 second.
3. Undervoltage relays shall be of a one or three phase voltage sensing type. They shall operate to trip the utility intertie circuit breaker at no less than 80 percent of the nominal voltage level (96 volts on a 120 volt nominal base). The normal maximum time delay to trip the intertie circuit breaker for small generators or generators with a limited parallel operating time will be 1.0 second. Medium and large generators having extended parallel operating times will typically have tripping time delays of 3.0 seconds. These time delays will be determined and established with the interconnection studies. Any intentional time delay in automatically closing the utility intertie circuit breaker after an undervoltage relay opens its trip contact should not be greater than 7.0 seconds unless Customer's load is in the process of being placed on Customer's generator through an open transition transfer or is already transferred to the Customer's generator.
4. Negative sequence overvoltage relays shall be of the three phase voltage sensing type and be capable of detecting 5 percent negative sequence voltage (6 volts on a 120 volt base) or less. The maximum time delay for this relay to trip the utility intertie circuit breaker shall be no greater than 1.0 second. Medium and large generators having extended parallel operating times will typically have tripping time delays of 3.0 seconds. These time delays will be determined and established with the interconnection studies. All closing of the utility intertie circuit breaker, including manual closing, shall be blocked while this relay is operating for a negative sequence condition. Any intentional time delay in automatically closing the utility intertie circuit breaker after the negative sequence relay opens its trip contact should not be greater than 7.0 seconds unless Customer's load is in the process of being placed on Customer's generator through an open transition transfer or is already transferred to the Customer's generator.

5. Overfrequency relays shall operate to trip the utility intertie circuit breaker at no greater than 63 hertz with a maximum time delay of 1.5 second. The typical setting for overfrequency relay tripping is 60.5 hertz with a maximum time delay of 167 milliseconds. Installations which are allowed extended parallel operation will have settings determined in conjunction with the interconnections studies.
6. Underfrequency relays shall operate to trip the utility intertie circuit breaker at no less than 54 hertz with a maximum time delay of 1.5 second. The typical setting for installations which are allowed only limited parallel operation will be 59.5 hertz with a maximum time delay of 167 milliseconds. Installations which are allowed extended parallel operation will have settings determined in conjunction with the interconnection studies. Typical underfrequency trip settings for medium and large generators are 57.0 Hz with a time delay of 167 milliseconds.
7. Reverse power relays (power flowing from the Customer to the Company) shall operate to trip the utility intertie circuit breaker for a power flow no greater than 4 percent of the maximum power generation capability of the customer's generator(s) with a maximum time delay of 1.0 second. This relay will be required for all installations except when Customer is specifically allowed to sell power to Company or across Company's electric system. If the reverse power relay is an instantaneous operating type, a Utility Grade time delay relay can be added to provide time delayed operation to help avoid nuisance trips.
8. A parallel limit timing relay set at a maximum of 180 seconds shall trip either the utility intertie circuit breaker or the generator circuit breaker. This relay may be either a Utility Grade relay or a plug-in type Industrial Grade relay. This relay will be required for all installations allowing only limited parallel operation. When a Customer is specifically required to operate in parallel with Company's system for a period beyond 180 seconds to satisfy a Company required soft load transfer, the parallel limit timer setting will be increased to satisfy the requirement. The parallel limit timing relay is not required when the allowed Customer parallel operation time is not limited.
9. A zero sequence definite time overvoltage detection relay scheme will be required with delta connected, ungrounded wye or impedance grounded windings on the source side of the interconnection transformer. This relay scheme shall trip the utility intertie circuit breaker for phase-to-ground faults on the source side of the transformer. This relay requires time coordination for fault clearing on Company's system. Time delay requirements will be determined by the interconnection studies, but are typically 3.0 seconds. This scheme requires phase-to-ground potential sensing device(s) located on the source side of the transformer, and may have two configurations. The first scheme has three potential sensing devices with their secondaries connected in an "open delta" connection. If the potential devices are selected to provide a maximum of 345 volts across the open corner of the delta, an overvoltage relay having a maximum continuous rating of 345 volts and capable of operating on 55 volts or more is connected across the open corner of the delta. If the potential devices are selected to provide a maximum of 208 volts across the open corner of the delta, an overvoltage relay of this continuous rating capable of operating on 20 volts or more is used. In either case, a ballast resistor should also be installed across the open corner of the delta to prevent ferroresonance in the potential sensing devices. This resistor is typically sized to load the potential transformers to 30% of the transformers combined thermal capacity. The second scheme has a single potential sensing device with overvoltage and undervoltage operating relays. The overvoltage relay should trip at 110% of nominal voltage level (132 volts on a 120 volt base). The undervoltage relay should trip at 80% of nominal voltage level (96 volts on a 120 volt base). Both relays should be continuously rated for 1.73 times nominal voltage (208 volts on a 120 volt base).

10. For generators connected directly to Company's system without an interconnection transformer or if the required transformer connection is grounded-wye on the transformer's high voltage side and delta on the transformer's low voltage side, a special sensitive ground fault detection relay scheme may be required. This scheme may consist of a sensitive ground detection relay at the generator location and a directional ground overcurrent relay at Company's substation with permissive transfer tripping over a communication channel between the two locations. At the 4kV and 12.47kV voltage levels a dedicated circuit may be required from Company's substation to the generator location. At higher voltage levels additional circuit breakers may be required at the generator point-of-interconnection. These interconnection requirements will be identified in the interconnection studies.
11. For generator installations having generators not limited to 180 seconds parallel operation time and not having zero sequence networks isolated from Company's system, a ground fault detection scheme will be required on the generator neutral. This is a backup function necessary due to the possibility of extremely low values of phase-to-ground fault current which may exist for a fault fed from the generator. The backup function requires this relay to be time coordinated with other ground fault protective devices. This scheme typically consists of a time overcurrent relay. This relay should be set as sensitive as possible but it should not operate for third harmonic currents present in the generator or for normal unbalance currents that appear in the neutral. The pickup setting of the overcurrent relay should be no less than 135% of the maximum value of current measured in the neutral under non-fault conditions.
12. For generator installations requiring extended parallel operating time, a voltage supervised time overcurrent protective scheme will be required on the generator. This backup function is required due to the increased possibility of failure of a primary protective device. The voltage supervised time overcurrent relay shall be one of two types. One type is a voltage restrained relay where the current pickup varies as a function of the voltage applied to the relay (as voltage decreases, the current pickup value decreases). A second type is a voltage controlled relay which is a sensitive low pickup time overcurrent relay that is torque controlled by an undervoltage relay. A voltage controlled relay is in service only during a fault or undervoltage condition. A voltage restrained relay will typically be required unless the interconnection studies indicate a voltage controlled relay must be used to obtain the required fault current sensitivity. The backup function requires this relay be time coordinated with other phase fault protective devices.
13. For medium or large generator installations which will operate in parallel with Company's system beyond 180 seconds and having fused transformers or feeders, a negative sequence overcurrent relay will be required. This relay will protect other Company customers from being supplied unbalanced power if they become islanded on the Customer's generator. This relay shall be capable of detecting and tripping a negative-sequence current value between 5% and 10% of the generator continuous balanced current rating. Negative sequence time-current capability curves must be supplied by the generator manufacturer to determine the setting required. This backup function requires time coordination with the primary phase fault detection devices. Tripping from this relay should be supervised by 52a switches of the generator circuit breaker and of the utility tie circuit breaker to prevent tripping by this relay except when the generator is actually operating in parallel with Company's electric system when both circuit breakers are closed.
14. Relaying modifications may be necessary at Company's source substation which includes installation of phase and ground directional overcurrent relays for medium and large generator classifications if coordination between protective devices on Company's and Customer's system becomes critical. It may also be necessary to combine this modification with permissive transfer tripping over a communication channel between Company's

substation and the interconnection location as mentioned previously. This relaying requirement will be identified in the interconnection studies.

15. All changes in relays or relay settings desired by Customer after initial installation must have written approval of Company.
16. All relays shall meet the following tolerances over the entire anticipated operating temperature range for their respective physical locations. If these tolerances cannot be maintained, higher quality relays or environmental conditioning (additional heating or cooling) to reduce the anticipated operating temperature range may be required.
  - a. Voltage: plus/minus 3% of required setting
  - b. Current: plus/minus 3% of required setting
  - c. Time: plus/minus 5% of required setting
  - d. Frequency: plus/minus 0.2 hertz from required setting
  - e. Phase angle: plus/minus 3 degrees from required setting

Company's policy is that Customer determine the relay settings required for protection at Customer's installation. Proposed relay settings shall fall within the guidelines for each particular relay as indicated above. Proposed settings shall be submitted to Company for approval. This submittal shall be made no later than in conjunction with the required "Pre-Qualification Testing" submittal.

All interconnection protective relays should be visually inspected (but not removed from their case or physically disturbed) for any obvious signs of damage or inoperability at least once per week. Any indication of relay inoperability shall be reported to Company immediately and requires temporary suspension of parallel operation until the appropriate inspections, tests and repairs have been completed.

The operation of any interconnection relay targets shall be reported to Company immediately.

#### D. Single-Phase Devices - Fuses/Oil Circuit Reclosers

Company's policy is to install sectionalizing equipment on radial circuits that tap the main circuit. This sectionalizing equipment is typically single phase fuses. It is also Company's policy to fuse the source side of its substation transformers.

Customer shall be aware that whether or not single-phase devices exist on Company's system, Customer is responsible for protecting Customer's generating equipment from the effects of excessive negative sequence currents.

#### E. Automatic Reclosing/Voltage Check Schemes

Company normally applies automatic reclosing to all transmission and distribution lines; and, Customer must insure that Customer's generation is disconnected from Company's system prior to automatic reclosing. It is normally necessary to install voltage check schemes at various locations on Company's system to prevent automatic reclosing in the event that Customer's generator remains connected to an isolated, unfaulted section of Company's system. Voltage check schemes shall be required on Company feeders as follows:

1. For all generator installations if instantaneous automatic reclosing is required on the Company circuit on which the generator is to be installed.



2. Company will time delay automatic reclosing by two seconds with a +/- 1.0 second tolerance to avoid the voltage check requirement for extremely small generators when possible to do so without deteriorating quality and reliability of service.
3. For all generator installations classified as small which are to operate in parallel with Company's system for periods of time exceeding 180 seconds.
4. For all medium or large generator installations.

Details of any modifications to Company's reclosing practices and/or addition of voltage check schemes will be determined during the interconnection studies. Company assumes no responsibility for damage to Customer's equipment due to out-of-phase reclosing.

#### F. Communication Channel

Company may require that a communication channel or channels be installed as part of the metering and protective scheme for Customer's interconnection. This channel may consist of power line carrier, pilot wire circuit, fiber optic cable, leased telephone line, or other means. The communication channel is required in certain cases for telemetering and/or where it is necessary for proper protective relay coordination which cannot be achieved by other means. The interconnection study will determine communication channel requirements.

#### G. Control Batteries

Reliable operation of the protective equipment is totally dependent upon the control battery for DC power. For this reason, proper maintenance is required on the control battery to insure performance.

At weekly intervals:

1. A visual inspection should be made of all cells for cracked jars, cracked plates, leaking electrolyte, condition of terminal posts, connections and cell electrolyte levels.
2. Water should be added to cells with low electrolyte levels.

At least once every six months, testing and maintenance should include checking specific gravity and temperature, voltage of each individual cell and total battery, charging current, etc. Corrections of any abnormal conditions must be made immediately.

Copies of maintenance records for the previous 3 years shall be kept on file and shall be made available to Company for inspection upon request. This will normally be done in conjunction with required inspection and testing of the protective relaying equipment.

### VII. TESTING REQUIRED FOR PARALLEL OPERATION

Testing of the intertie equipment and associated devices will be required to ensure their proper operation. Testing shall be performed prior to initial interconnection and at periodic intervals as requested by Company but not less than every four years thereafter. All required testing of Customer equipment shall be done at Customer expense. Costs incurred by Company to perform this inspection or any testing shall be reimbursed by Customer.

Induction generators or generation sources using inverters when the generation source is not self-excited shall comply with the "Initial Pre-qualifying Testing" detailed below except for testing of the synchronizing relay which would not apply. Testing of voltage variation upon connection to the electric system, voltage flicker and harmonic testing shall be performed on these types of generator installations. The other testing requirements detailed in "Open Transition Operation and Testing" and "Closed Transition Testing" sections do not apply.

Self-excited generators both with and without inverters shall comply with the "Initial Pre-qualifying Testing" the "Open Transition Operation and Testing" and with the "Closed Transition Testing" requirements detailed below.

Qualification testing shall not be performed on those days designated as holidays in the "Labor Agreement Between Montana-Dakota Utilities Co. and System Council U-13 of the International Brotherhood of Electrical Workers".

#### A. Initial Pre-qualifying Testing

Initial pre-qualifying testing shall be performed on site by a competent testing firm and witnessed by a Company representative prior to interconnection to any system served by Company. Customer shall provide Company with all of the following information at least three weeks prior to on site pre-qualifying testing:

1. Two complete sets of instruction books providing complete bench test procedures for all interconnection protective relays.
2. Proposed settings for all interconnection protective relays.
3. Two complete sets of drawings that are up-to-date for the equipment as it exists when available for test. The drawings should include, but not be limited to, a one-line diagram, AC and DC schematics, complete abbreviations list, outline diagram of physical arrangement of switchgear, inter-connection diagram, material list.
4. Two sets of instruction books providing complete mechanical and electrical checkout procedures for the utility intertie circuit breaker.
5. Final interconnection and generator data in accordance with Appendix "B" attached.

Customer is to provide written notice to Company at least two weeks prior to the desired date on which on site pre-qualifying testing is to be performed. Actual test times and dates will then be determined by mutual agreement. If there is conflict between Customer equipment or proposed relay settings and Company requirements, this conflict shall be resolved by negotiation and any required corrective action will be completed before commencement of pre-qualifying testing. Required pre-qualifying testing shall include but not be limited to the following:

1. Bench testing and setting of all interconnection relays.
2. Function testing which includes tripping of the utility intertie circuit breaker by all interconnection relays.
3. Injection of current and potential in secondary circuits, and verification that the correct quantities arrive at the correct locations.
4. Ratio tests of all current and potential transformers that provide secondary quantities to all interconnection relays.

5. Verification that DC control power fusing will remove control power from the control circuits exactly as indicated on the drawings.
6. Mechanical and electrical checkout of the utility intertie circuit breaker.
7. Demonstrate by external voltage injection that the synchronizing relay will attempt to close the generator circuit breaker or operate closed transition transfer switch within the limits stated in Section IV D herein. Necessary precautions are to be taken so closing of the generator circuit breaker or operation of the closed transition transfer switch does not improperly energize any load or equipment.

#### B. Open Transition Operation and Testing

After satisfactory completion of pre-qualifying testing, Company will give written notice to Customer that Customer's equipment may be connected to the system. Permission will be granted at this time for open transition operation and testing only.

#### C. Closed Transition Testing

Upon successful completion of open transition operation and testing by Customer, Customer shall provide written notice to Company two weeks prior to the desired date for qualifying closed transition testing. Actual test times and dates will be determined by mutual agreement. Qualifying closed transition testing shall be performed at Customer's expense and be performed on site by a competent testing firm and witnessed by a Company representative. Costs incurred by company to perform this inspection or any testing shall be reimbursed by Customer. Customer shall be aware that the required testing will result in several short interruptions of electric service to Customer's load that is to be served by the generator under test. If Customer's equipment fails to properly perform any of the following tests, qualifying testing will stop at that point. Company will provide written notice to Customer of the problem. No further qualifying testing will be done until the problem has been eliminated and the generator can only be operated with an open transition transfer. Customer shall be aware that, during the process of eliminating a problem, it may be necessary to repeat some of the pre-qualifying testing due to control wiring modification before closed transition qualifying testing will be resumed. Required qualifying closed transition testing shall include but not be limited to the following:

1. A rotation meter should be installed on Customer's system to verify proper rotation. If possible rotation meter should be installed at a location where Company rotation supplied to Customer can be verified, then Customer generator rotation can be verified prior to energizing any Customer load. If this is not possible, caution should be used so that no rotation sensitive load is energized from the Customer generator until generator rotation is verified as being the same as that supplied by Company. Voltage and loading levels should be measured. Current and voltage harmonic measurements should also be made at this time.
2. Demonstrate that the prime-mover can be started, that the generator can be brought up to speed, and that the prime-mover governor will control the generator frequency and maintain the generator at close to but slightly above system frequency. No load generator voltage levels should be checked at this time. Verify generator rotation at this time if possible.

3. Demonstrate that the prime-mover and generator will pickup load. This is to be an open transition test. Verify generator rotation at this time if it could not be done before picking up load. Voltage and loading level should be measured and verified to be similar to those measured when load was carried from system. While the generator is carrying load, harmonic testing will be done. If there is no increase in the harmonic levels measured, testing may be continued. If generator causes harmonic currents or voltages to rise above previously measured levels and these new measured levels are above the limits stated in Section IV A5 herein, testing will stop at this point and only open transition operation will be allowed until the cause is determined and remedied. For generators designed to automatically start and pickup Customer's load after loss of normal electric service, this test should be initiated by operation of the undervoltage/negative sequence relay used to provide this start command. The open transition transfer test is required to verify that a de-energized Company line will not be re-energized by Customer's generator during the load transfer process upon loss of Company source.
4. If harmonic currents and voltages are within acceptable limits, a closed transition re-transfer (Customer's load being re-transferred from the generator to the system) will be allowed. During this re-transfer, voltage levels, harmonic voltages, power flows, var flows and actual parallel time will be monitored.
5. If the above qualifying tests are successful, a closed transition transfer (Customer's load being transferred from the system to the generator) will be allowed. During this transfer, voltage levels, harmonic voltages, power flows, var flows and actual parallel time will be monitored. For an installation qualifying for an interruptible rate, this test is to be initiated by Company's load transfer contact or its equivalent.
6. For installations qualifying for an interruptible rate, Company's load transfer contact or its equivalent shall now be opened. A closed transition re-transfer should take place. During this re-transfer, voltage levels, harmonic voltages, power flows, var flows and actual parallel time will be monitored.

#### D. Parallel Operation

Upon successful completion of the above tests, Company will provide Customer written confirmation that Customer's generator may operate in parallel with Company's system as allowed by the agreement between the parties. Customer shall be aware that neither the inspection nor the granting of approval to Customer shall serve to relieve Customer of any liability for injury, death or damage attributable to the negligence of Customer.

#### E. Re-Qualification Testing

At periodic intervals as requested by Company, but not less than every four years thereafter, re-qualification testing will be required. Required re-qualifying testing shall include but not be limited to the required tests and procedures set forth in Sections VII A, VII B and VII C herein. All costs incurred by Company to perform inspection and any testing shall be reimbursed by Customer.

Upon successful completion of the re-qualification tests, Company will provide the customer with written permission that Customer's generator may continue to be operated in parallel with Company's system.

## F. Electric Service Interruptions During Testing

Customer shall be aware that interruptions to electric service are required to perform the above specified testing. Testing is a requirement for parallel operation. If Customer fails to allow testing as required in this document, Company will provide written notice to Customer that all allowed parallel operation shall cease immediately and further parallel operation is prohibited until the required testing is completed in a manner satisfactory to Company.

If the Customer finds the reality of several short interruptions to electric service unacceptable, a means of bypassing shall be installed. A bypass may take several forms depending upon the equipment arrangements. One type may consist of a bypass-isolation switch which is an integral part of a closed-transition transfer switch. This combination when properly designed will allow most re-qualification testing and maintenance to be performed on the utility breaker, generator breaker or the transfer switch without interrupting load.

A second type bypass, when only a utility breaker and generator breaker are used, requires the bypass to be connected from the utility side of the utility intertie circuit breaker to Customer's load bus. The bypass device shall provide a visible air gap between the Customer's generating equipment and Company's system in order to establish the required safety requirements for maintenance and repair work on Company's system. A means of interlocking between the generator breaker or another visible break lockable disconnecting device and the bypass shall be provided such that the generator breaker or a lockable disconnect must be open, racked-out or otherwise be made impossible to put into service and close before the bypass can be closed and until after the bypass is opened. The bypass shall also be equipped with a Company lock permitting operation of the bypass by authorized Company personnel only. The bypass device must be properly rated to handle the load placed on it. Written approval from Company will be required before installation of bypass equipment to any system served by Company will be permitted. Customer must submit full details of the bypass to Company for approval. All required bypass equipment, installation and qualification testing of that equipment shall be at Customer expense.

Customer shall be aware that even with bypass equipment, a momentary interruption will still occur when an open transition transfer test of the generator is required or if the prime mover and/or generator fail to perform correctly on any type of load test. The open transition transfer test is required to verify that a de-energized Company line will not be re-energized by Customer's generator during the load transfer process upon loss of Company source. The open transition transfer test can be scheduled at a different time from the other re-qualification testing when necessary to do so for the convenience of the Customer.

## VIII. OPERATING GUIDELINES

Customer shall operate Customer's generating equipment within the guidelines of this document and any special requirements set forth in the agreement between the parties. Company reserves the right to open the intertie circuit breaker or disconnect device or to withdraw permission for parallel operation for any of the following reasons:

1. A Company system emergency.
2. Inspection of Customer's generating and protective equipment reveals a hazardous condition or a lack of scheduled maintenance and testing.
3. Failure of Customer to provide maintenance and testing reports to Company as required.

4. Customer's generating equipment interferes with other Company customers or with the operation of Company's system.
5. Customer has modified Customer's generating equipment or protective devices without the knowledge or written approval of Company.
6. Parallel operation without written approval from Company for parallel operation.
7. Parallel operation after Customer has been ordered by Company in writing to cease all parallel operation.
8. Personal safety is threatened.

#### IX. FUTURE CHANGES

Customer shall be aware that changes to Company's system, the addition of other Customer-Owned generation in the same vicinity, or deficiencies in the Customer's equipment, may require modifications to the interconnection protective devices. If such changes are required, Customer may be subject to future charges for these modifications.

**APPENDIX "A"**

**ONE-LINE DIAGRAMS  
OF  
TYPICAL INTERCONNECTIONS WITH GENERATION**

**INDEX**

<b>FIGURE</b>	<b>DESCRIPTION</b>
<b>Extremely Small Generation</b>	
1	1-Phase Inverter or Generator, One or Two Way Flow
1A	3-Phase Inverter or Generator, One or Two Way Flow
1B	1-Phase Inverter or Generator, Limited Parallel Operation, One-Way Flow
1C	3-Phase Inverter or Generator, Limited Parallel Operation, One-Way Flow
<b>Small Generation</b>	
2	Limited Parallel Operation, One-Way Flow
2A	One-Way Flow
2B	One or Two Way Flow
<b>Medium Generation - With Transformer</b>	
3	Below 5000 kVA, Limited Parallel Operation, One-Way Flow
3A	Below 5000 kVA, One-Way Flow, Y- $\Delta$ Transformer
3A1	Below 5000 kVA, One-Way Flow, Y-Y Transformer
3B	Below 5000 kVA, One or Two Way Flow, Y- $\Delta$ Transformer
3B1	Below 5000 kVA, One or Two Way Flow, Y-Y Transformer
3C	41.6 or 60kV, Limited Parallel Operation, One-Way Flow
3D	41.6 or 60kV, One-Way Flow, Y- $\Delta$ Transformer
3D1	41.6 or 60kV, One-Way Flow, $\Delta$ -Y Transformer
3E	41.6 or 60kV, One or Two Way Flow, Y- $\Delta$ Transformer
3E1	41.6 or 60kV, One or Two Way Flow, $\Delta$ -Y Transformer
<b>Medium Generation - Direct Connected to Distribution</b>	
3F	Below 5000 kVA, Limited Parallel Operation, One-Way Flow
3G	Below 5000 kVA, One-Way Flow
3H	Below 5000 kVA, One or Two Way Flow
<b>Large Generation</b>	
4	Limited Parallel Operation, One-Way Flow
4A	One-Way Flow, Y- $\Delta$ Transformer
4A1	One-Way Flow, $\Delta$ -Y Transformer
4B	One or Two Way Flow, Y- $\Delta$ Transformer
4B1	One or Two Way Flow, $\Delta$ -Y Transformer

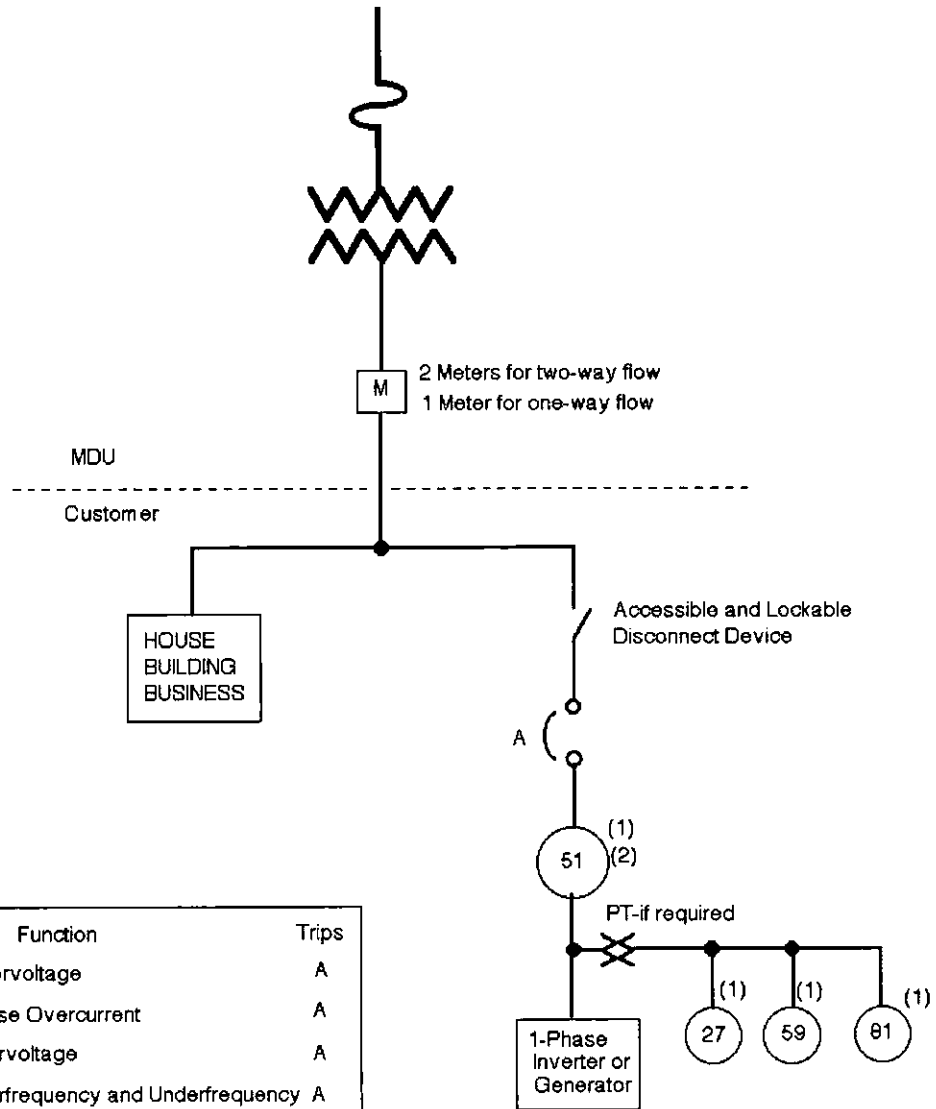

MDU Distribution System (12.5kV and below)



Device No.	Function	Trips
27	Undervoltage	A
51	Phase Overcurrent	A
59	Overvoltage	A
81	Overfrequency and Underfrequency	A

(1) (2) (3) Indicates Number of Phases Monitored

Typical Distribution Interconnection with One-Way or Two-Way Power Flow

	EXTREMELY SMALL GENERATION FIGURE 1	
	<b>MONTANA-DAKOTA UTILITIES CO.</b>	
DATE: 12/8/89	MONTANA-DAKOTA UTILITIES CO.	DRAWING NO: 012591-1
APPROVED: 11/5/98 dhr 8/10/00 dhr	ADD PT Divided 27 & 59	FILE NO: 51-1010
DATE BY REVISION	DATE BY REVISION	DATE BY REVISION



MDU Distribution System (12.5kV and below)

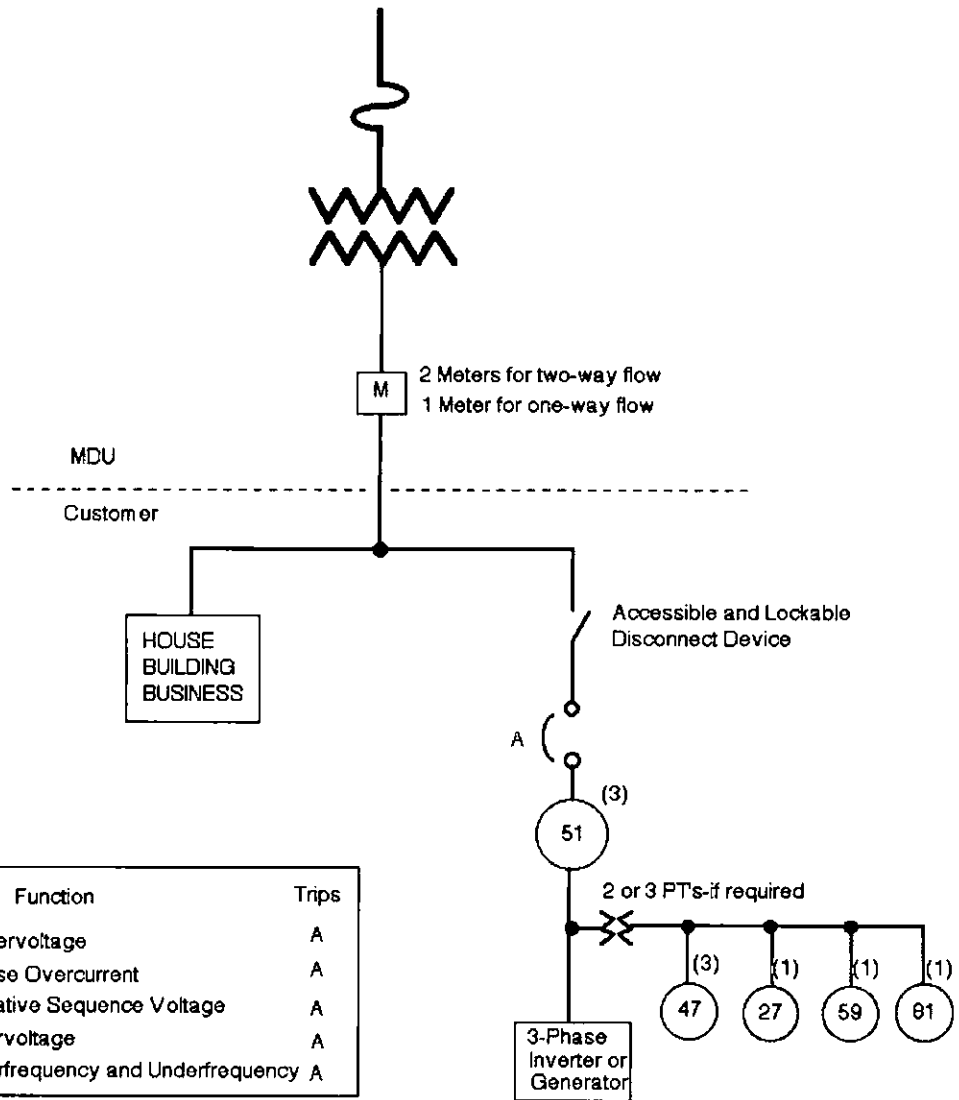

Device No.	Function	Trips
27	Undervoltage	A
51	Phase Overcurrent	A
47	Negative Sequence Voltage	A
59	Overvoltage	A
81	Overfrequency and Underfrequency	A

(1)(2)(3) Indicates Number of Phases Monitored

Typical Distribution Interconnection with One-Way or Two-Way Power Flow

	EXTREMELY SMALL GENERATION		
	FIGURE 1A		
DATE: 12/8/89	<b>MONTANA-DAKOTA UTILITIES CO.</b>		DRAWING NO: 012591-1A
APPROVED:	11/5/98 chr 8/10/01 chr	ADR PT Divided 47 Function	FILE NO: <b>51-1011</b>
	DATE	BY	REVISION

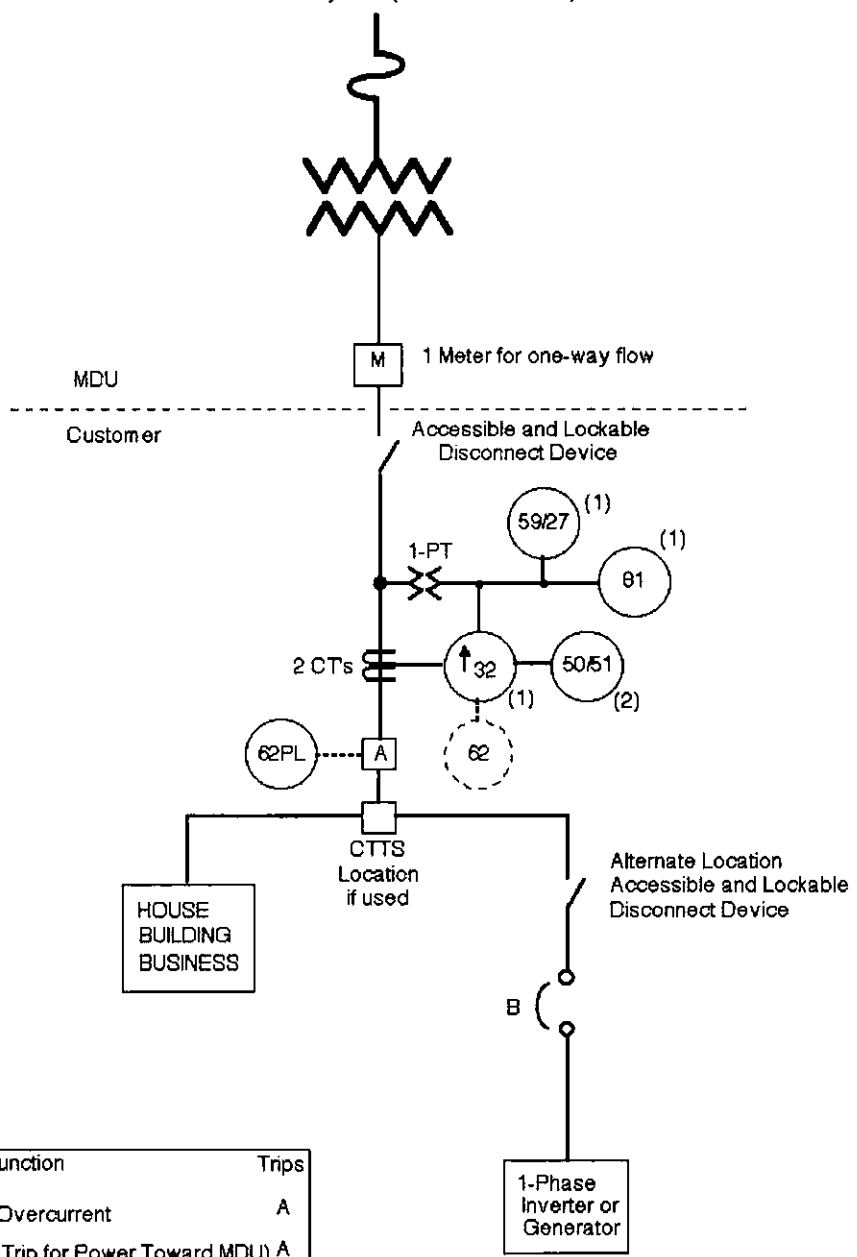

MDU Distribution System (12.5kV and below)



Device No.	Function	Trips
50/51	Phase Overcurrent	A
32	Power (Trip for Power Toward MDU)	A
59/27	Overvoltage and Undervoltage (Not required with CTTS<100mS)	A
62	Optional Time Delay relay for 32	A
62PL	Parallel Limit Timer	A
81	Over / Under Frequency (Not required with CTTS<100mS)	A
CTTS	Closed Transition Transfer Switch	

(1)(2)(3) Indicates Number of Phases Monitored

Typical Distribution Interconnection with One-Way Power Flow Limited Parallel Operation

	EXTREMELY SMALL GENERATION		
	FIGURE 1B		
DATE: 11/06/98	MONTANA-DAKOTA UTILITIES CO.		DRAWING NO: 110698-1
APPROVED:			FILE NO: 51-1012
	DATE	BY	REVISION

MDU Distribution System (12.5kV and below)

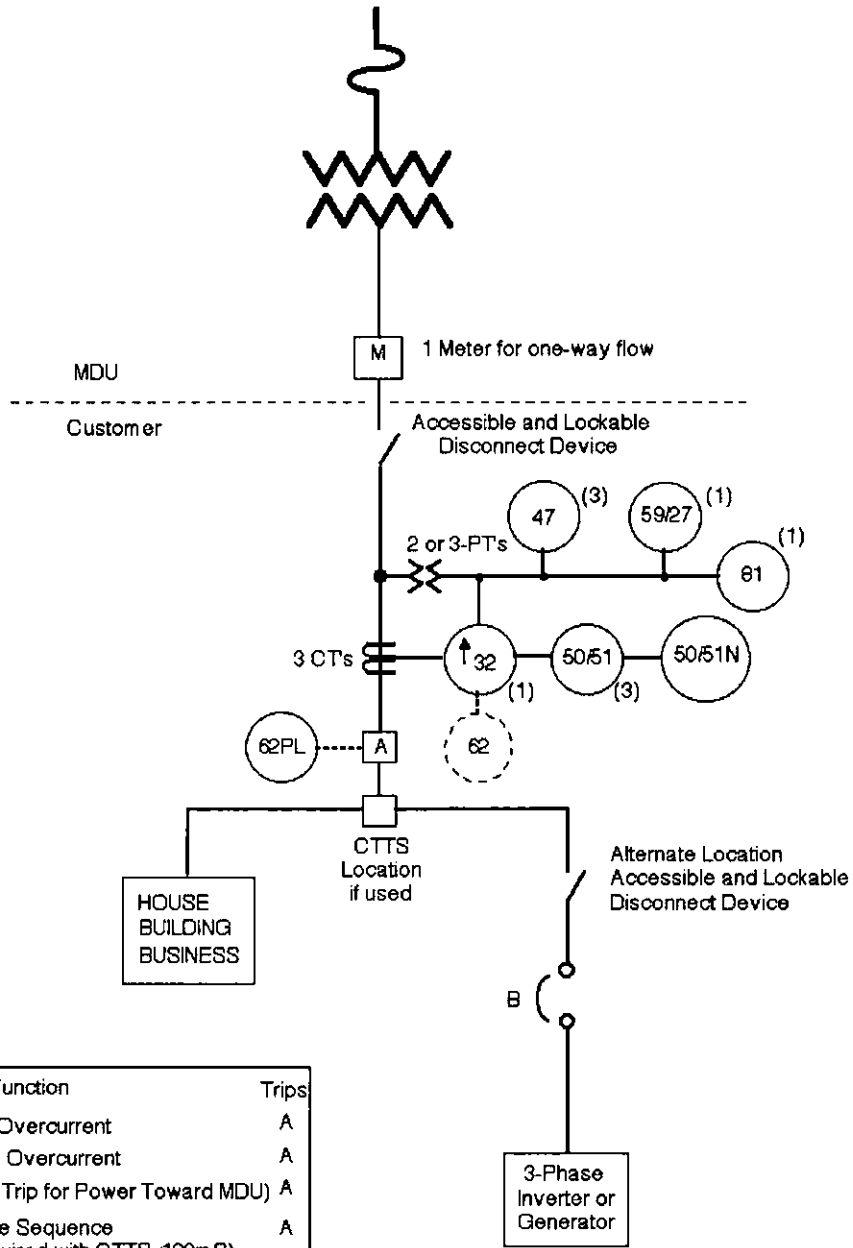

Device No.	Function	Trips
50/51	Phase Overcurrent	A
50/51N	Ground Overcurrent	A
32	Power (Trip for Power Toward MDU)	A
47	Negative Sequence (Not required with CTTS<100mS)	A
59/27	Overvoltage and Undervoltage (Not required with CTTS<100mS)	A
62	Optional Time Delay relay for 32	A
62PL	Parallel Limit Timer	A
61	Over / Under Frequency (Not required with CTTS<100mS)	A
CTTS	Closed Transition Transfer Switch	

(1)(2)(3) Indicates Number of Phases Monitored

Typical Distribution Interconnection with One-Way Power Flow Limited Parallel Operation

	EXTREMELY SMALL GENERATION	
	FIGURE 1C	
DATE: 11/06/98	<b>MONTANA-DAKOTA UTILITIES CO.</b>	DRAWING NO: 110698-2
APPROVED:	B/10/07 chr	FILE NO: 51-1013
	DATE BY REVISION	
		Divided 47 to 47 & 27

MDU Distribution System (12.5kV and below)

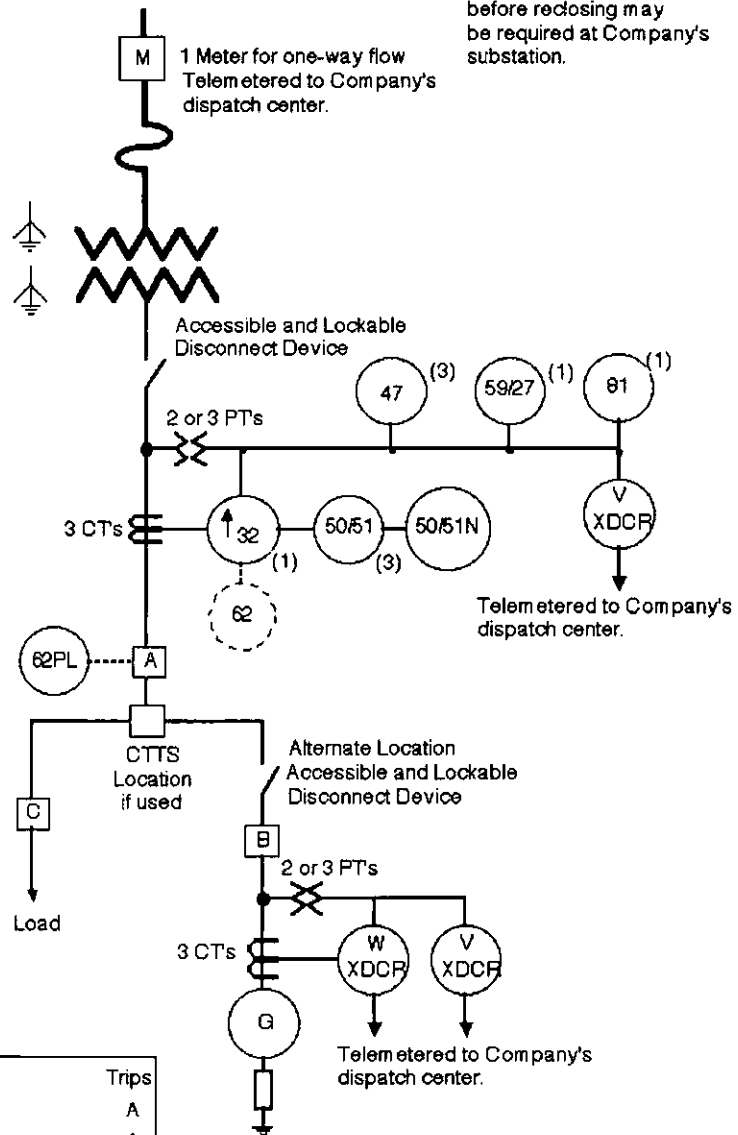

Note: Line voltage checking before reclosing may be required at Company's substation.



Device No.	Function	Trips
50/51	Phase Overcurrent	A
50/51N	Ground Overcurrent	A
32	Power (Trip for Power Toward MDU)	A
47	Negative Sequence Voltage (Not required with CTTS<100mS)	A
59/27	Overtvoltage and Undervoltage (Not required with CTTS<100mS)	A
62	Optional Time Delay relay for 32	A
62PL	Parallel Limit Timer	A
81	Over / Under Frequency (Not required with CTTS<100mS)	A
CTTS	Closed Transition Transfer Switch	

(1)(2)(3) Indicates Number of Phases Monitored

Typical Distribution Interconnection with One-Way Power Flow  
Limited Parallel Operation

		SMALL GENERATION FIGURE 2	
DATE: 12/8/89	<b>MONTANA-DAKOTA UTILITIES CO.</b>		DRAWING NO: 012591-2
APPROVED:	8/10/07 dhr 11/06/98 dhr	Separate voltage functions add CTTS	FILE NO: 51-1020
	DATE	BY	REVISION

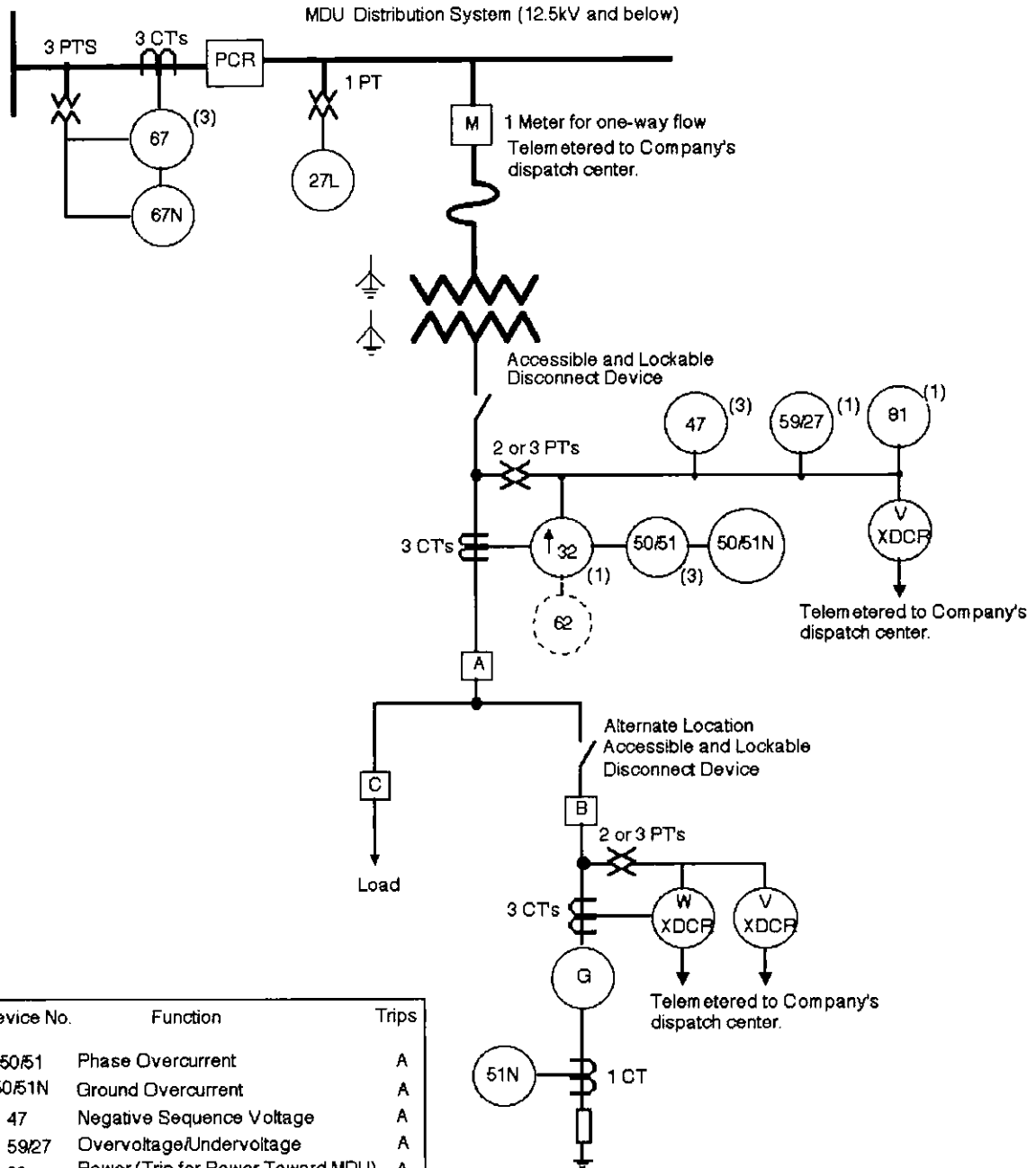

Device No.	Function	Trips
50/51	Phase Overcurrent	A
50/51N	Ground Overcurrent	A
47	Negative Sequence Voltage	A
59/27	Overtoltage/Undervoltage	A
32	Power (Trip for Power Toward MDU)	A
62	Optional Time Delay relay for 32	A
46	Negative sequence overcurrent	A
81	Overfrequency and Underfrequency	A
51V	Voltage Supervised Overcurrent	B
27L	Undervoltage (Reclose Supv)	
67	Directional Overcurrent	
67N	Directional Ground Overcurrent	

(1)(2)(3) Indicates Number of Phases Monitored

Typical Distribution Interconnection with One-Way Power Flow

	SMALL GENERATION		
	FIGURE 2A		
DATE: 12/8/89	MONTANA-DAKOTA UTILITIES CO.		DRAWING NO: 012591-2A
APPROVED:	8/18/02 dnr Separate Voltage Functions	FILE NO:	
	1/25/79 J.YEL ADD FILE NUMBERS	51-1021	
	DATE BY REVISION		

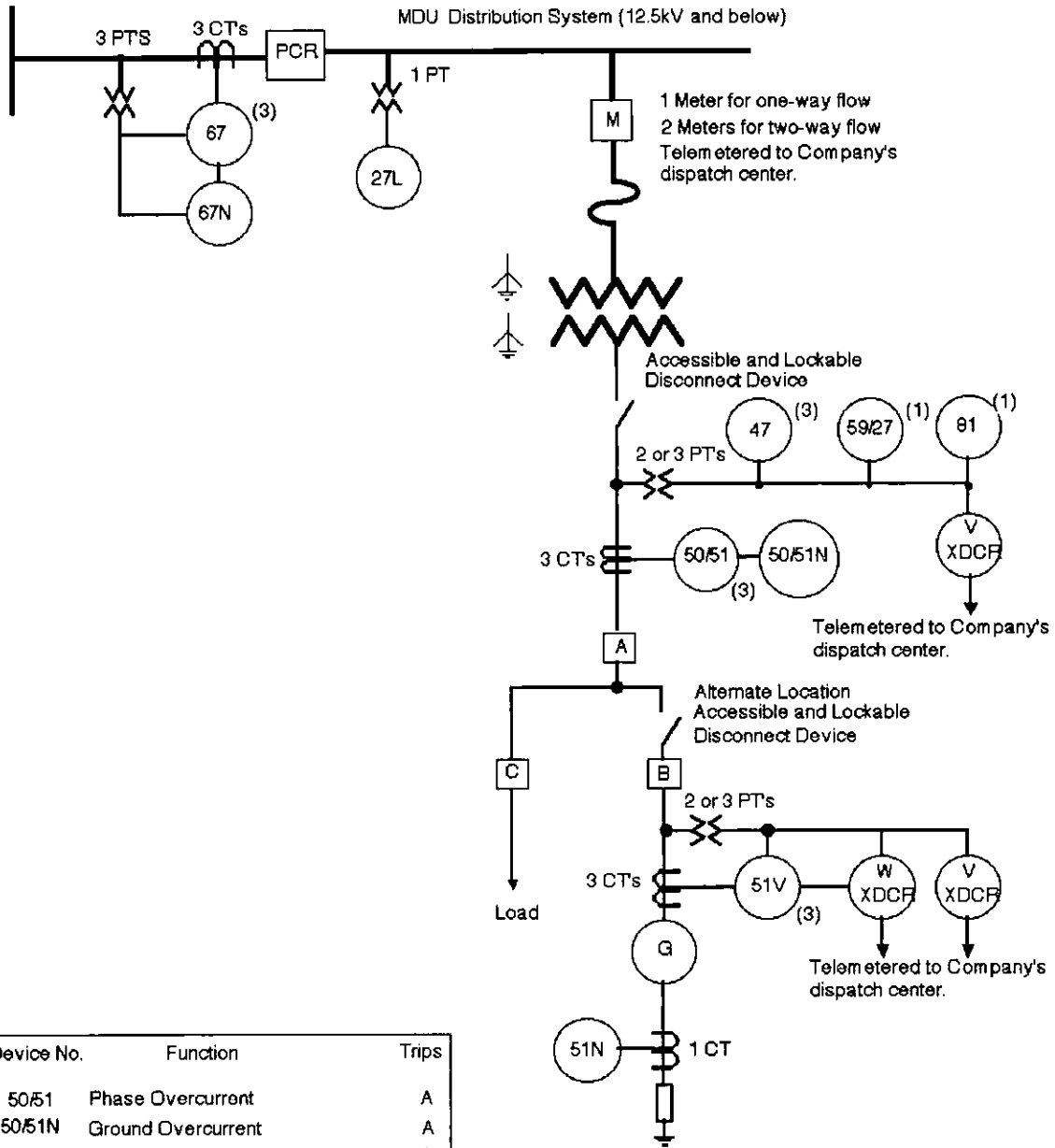

Typical Distribution Interconnection  
With One or Two Way Flow

Device No.	Function	Trips
50/51	Phase Overcurrent	A
50/51N	Ground Overcurrent	A
47	Negative Sequence Voltage	A
59/27	Overvoltage/Undervoltage	A
32	Power (Trip for Power Toward MDU)	A
62	Optional Time Delay relay for 32	A
46	Negative sequence overcurrent	A
81	Overfrequency and Underfrequency	A
51V	Voltage Supervised Overcurrent	B
27L	Undervoltage (Reclose Supv)	
67	Directional Overcurrent	
67N	Directional Ground Overcurrent	

(1)(2)(3) Indicates Number of Phases Monitored

MD		SMALL GENERATOR		DRAWING NO.	
		FIGURE 2B		012591-2B	
DATE:		MONTANA-DAKOTA UTILITIES CO.		FILE NO:	
12/8/89				51-1022	
APPROVED:		1/25/91 J.YEIL		DATE	
		8/10/01 dhr		BY	
		ADD FILE NUMBERS		REVISION	
		Separate Voltage Functions			

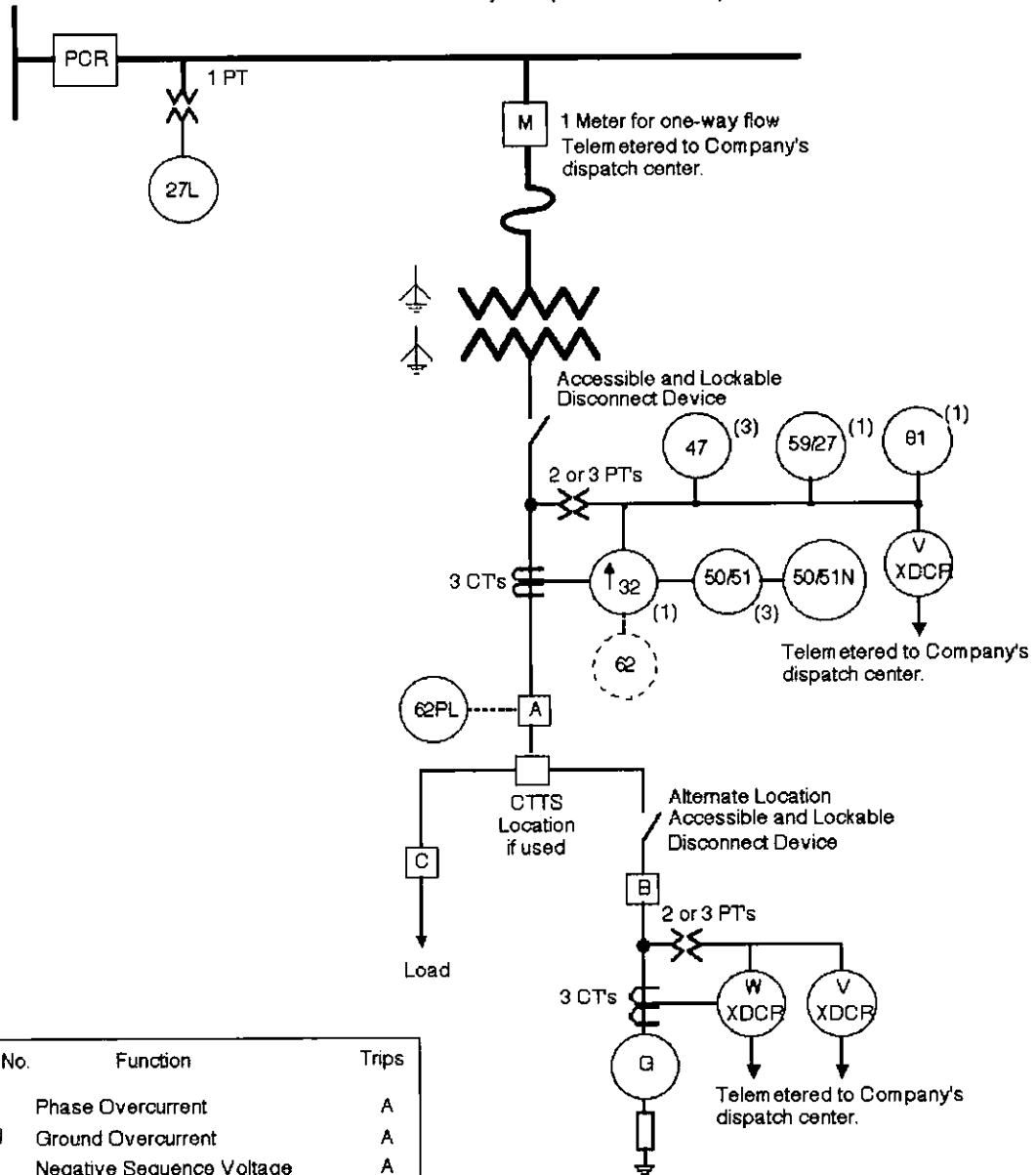

MDU Distribution System (12.5kV and below)



Device No.	Function	Trips
50/51	Phase Overcurrent	A
50/51N	Ground Overcurrent	A
47	Negative Sequence Voltage	A
59/27	Overvoltage/Undervoltage	A
32	Power (Trip for Power Toward MDU)	A
62	Optional Time Delay relay for 32	A
81	Overfrequency and Underfrequency	A
62PL	Parallel Limit Timer	A
27L	Undervoltage (Reclose Supv)	
CTTS	Closed Transition Transfer Switch (Soft Transfer Required)	

(1)(2)(3) Indicates Number of Phases Monitored

Typical Distribution Interconnection with One-Way Power Flow  
Limited Parallel Operation

		MEDIUM GENERATOR BELOW 5000 KVA FIGURE 3		
		<b>MONTANA-DAKOTA                  UTILITIES CO.</b>		
DATE:		12/8/89		DRAWING NO:
				012591-3
APPROVED:		11/06/98 dhr Add CTTS		FILE NO:
		8/10/07 dhr Separate Voltage Functions		
DATE		BY		REVISION
				51-1030

MDU Distribution System (12.5kV and Below)

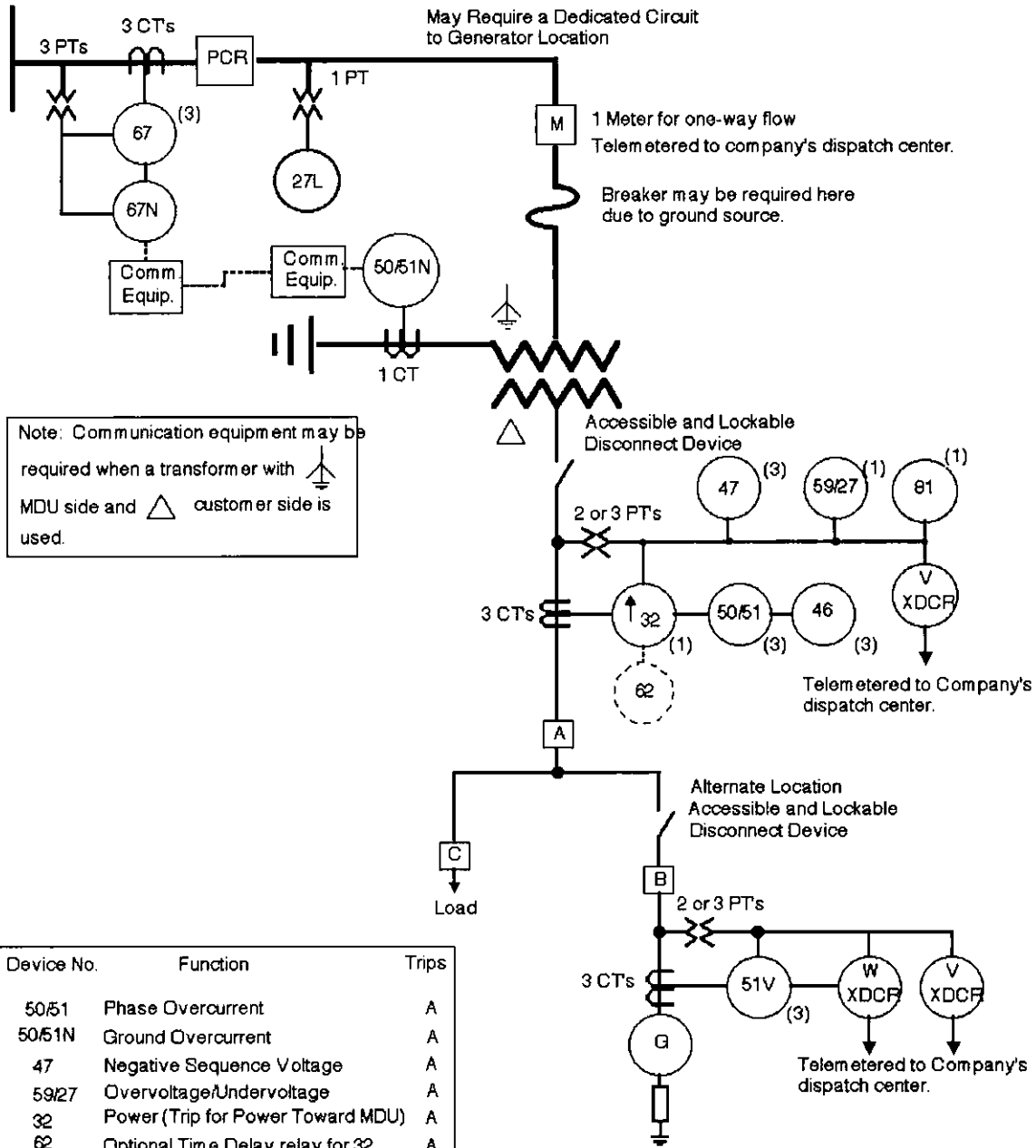

Note: Communication equipment may be required when a transformer with MDU side and Δ customer side is used.

Device No.	Function	Trips
50/51	Phase Overcurrent	A
50/51N	Ground Overcurrent	A
47	Negative Sequence Voltage	A
59/27	Overvoltage/Undervoltage	A
32	Power (Trip for Power Toward MDU)	A
62	Optional Time Delay relay for 32	A
46	Negative sequence overcurrent	A
81	Overfrequency and Underfrequency	A
51V	Voltage Supervised Overcurrent	B
27L	Undervoltage (Redose Supv)	
67	Directional Overcurrent	
67N	Directional Ground Overcurrent	

(1)(2)(3) Indicates Number of Phases Monitored

Typical Distribution Interconnection with One-Way Power Flow

		MEDIUM GENERATOR BELOW 5000 KVA FIGURE 3A			
		DATE: 12/8/89	<b>MONTANA-DAKOTA                  UTILITIES CO.</b>		DRAWING NO: 012591-3A
APPROVED:		11/06/98 dhr 07/10/07 dhr	Add 51V Separate Voltage Functions	FILE NO: 51-1031	
		DATE	BY	REVISION	



MDU Distribution System (12.5kV and Below)

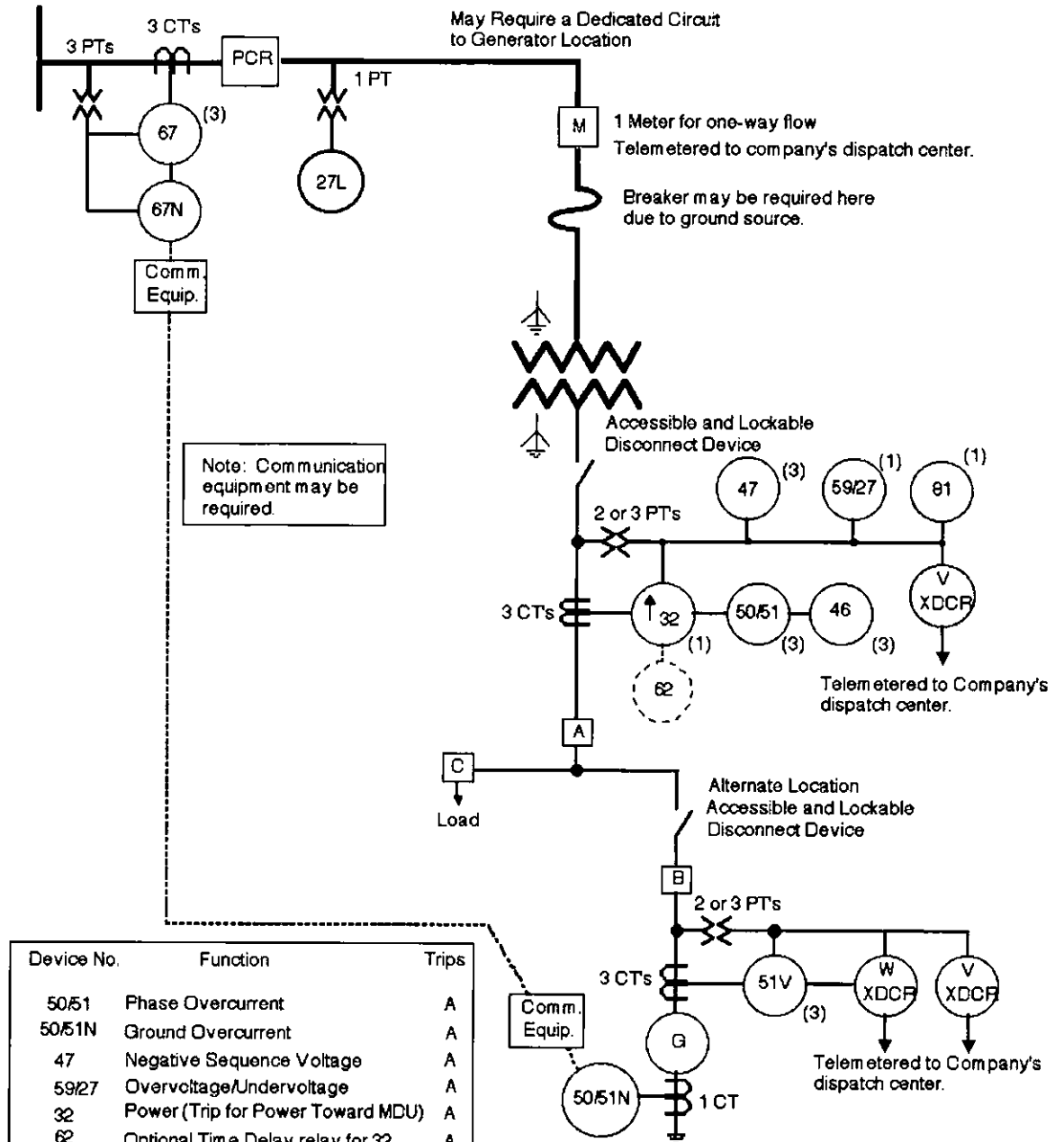

Note: Communication equipment may be required

Device No.	Function	Trips
50/51	Phase Overcurrent	A
50/51N	Ground Overcurrent	A
47	Negative Sequence Voltage	A
59/27	Overvoltage/Undervoltage	A
32	Power (Trip for Power Toward MDU)	A
62	Optional Time Delay relay for 32	A
46	Negative sequence overcurrent	A
81	Overfrequency and Underfrequency	A
51V	Voltage Supervised Overcurrent	B
27L	Undervoltage (Reclose Supv)	
67	Directional Overcurrent	
67N	Directional Ground Overcurrent	

(1)(2)(3) Indicates Number of Phases Monitored

Typical Distribution Interconnection with One-Way Power Flow

	MEDIUM GENERATOR BELOW 5000 KVA FIGURE 3A1		
	DATE: 8/10/07	<b>MONTANA-DAKOTA                  UTILITIES CO.</b>	
APPROVED:	DATE	BY	FILE NO: 51-1031-1
		REVISION	

MDU Distribution System (12.5kV and Below)

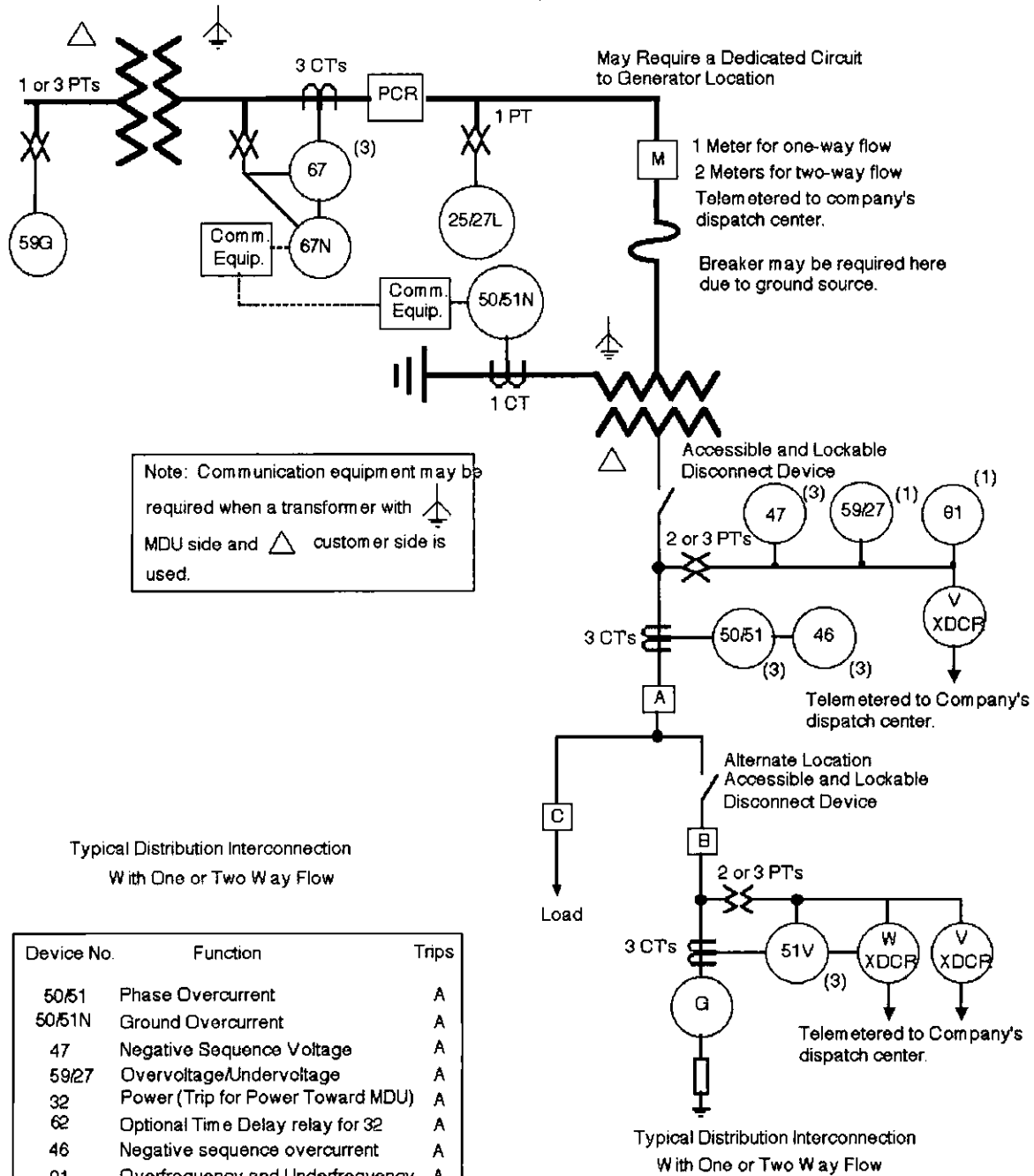

Device No.	Function	Trips
50/51	Phase Overcurrent	A
50/51N	Ground Overcurrent	A
47	Negative Sequence Voltage	A
59/27	Overvoltage/Undervoltage	A
32	Power (Trip for Power Toward MDU)	A
62	Optional Time Delay relay for 32	A
46	Negative sequence overcurrent	A
81	Overfrequency and Underfrequency	A
51V	Voltage Supervised Overcurrent	B
67	Directional Overcurrent	
67N	Directional Ground Overcurrent	
25/27L	Synch-Check/Line Voltage Check	
59G	Ground-Overvoltage	

(1)(2)(3) Indicates Number of Phases Monitored

		MEDIUM GENERATOR BELOW 5000 KVA FIGURE 3B		
		DATE: 12/8/89	<b>MONTANA-DAKOTA                  UTILITIES CO.</b>	
APPROVED:		11/06/98 dhr 8/10/07 dhr	Ground source note Separate Voltage Functions	FILE NO: 51-1032
		DATE	BY	REVISION

MDU Distribution System (12.5kV and Below)

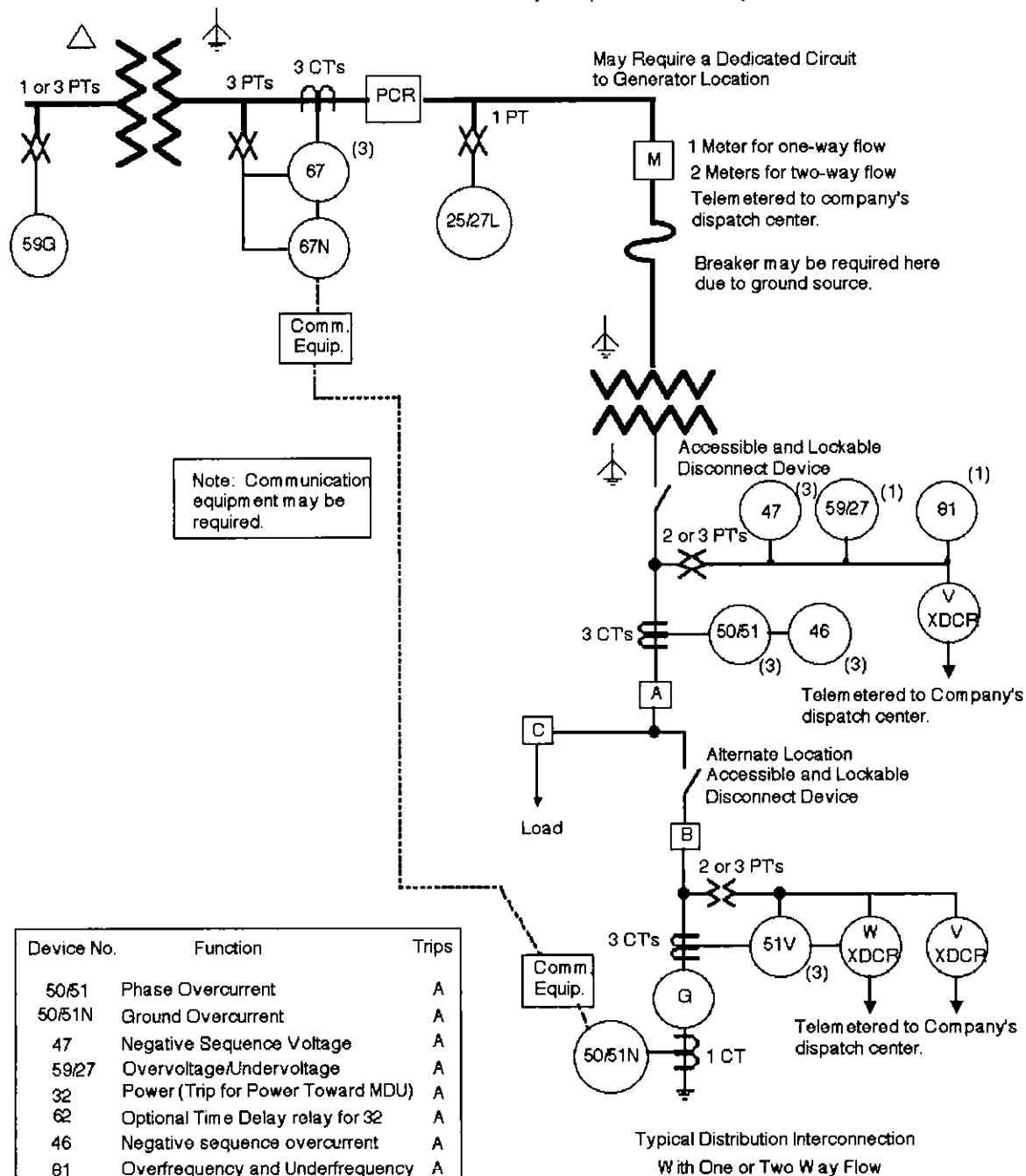

Device No.	Function	Trips
50/51	Phase Overcurrent	A
50/51N	Ground Overcurrent	A
47	Negative Sequence Voltage	A
59/27	Overvoltage/Undervoltage	A
32	Power (Trip for Power Toward MDU)	A
62	Optional Time Delay relay for 32	A
46	Negative sequence overcurrent	A
81	Overfrequency and Underfrequency	A
51V	Voltage Supervised Overcurrent	B
67	Directional Overcurrent	
67N	Directional Ground Overcurrent	
25/27L	Synch-Check/Line Voltage Check	
59G	Ground-Overvoltage	

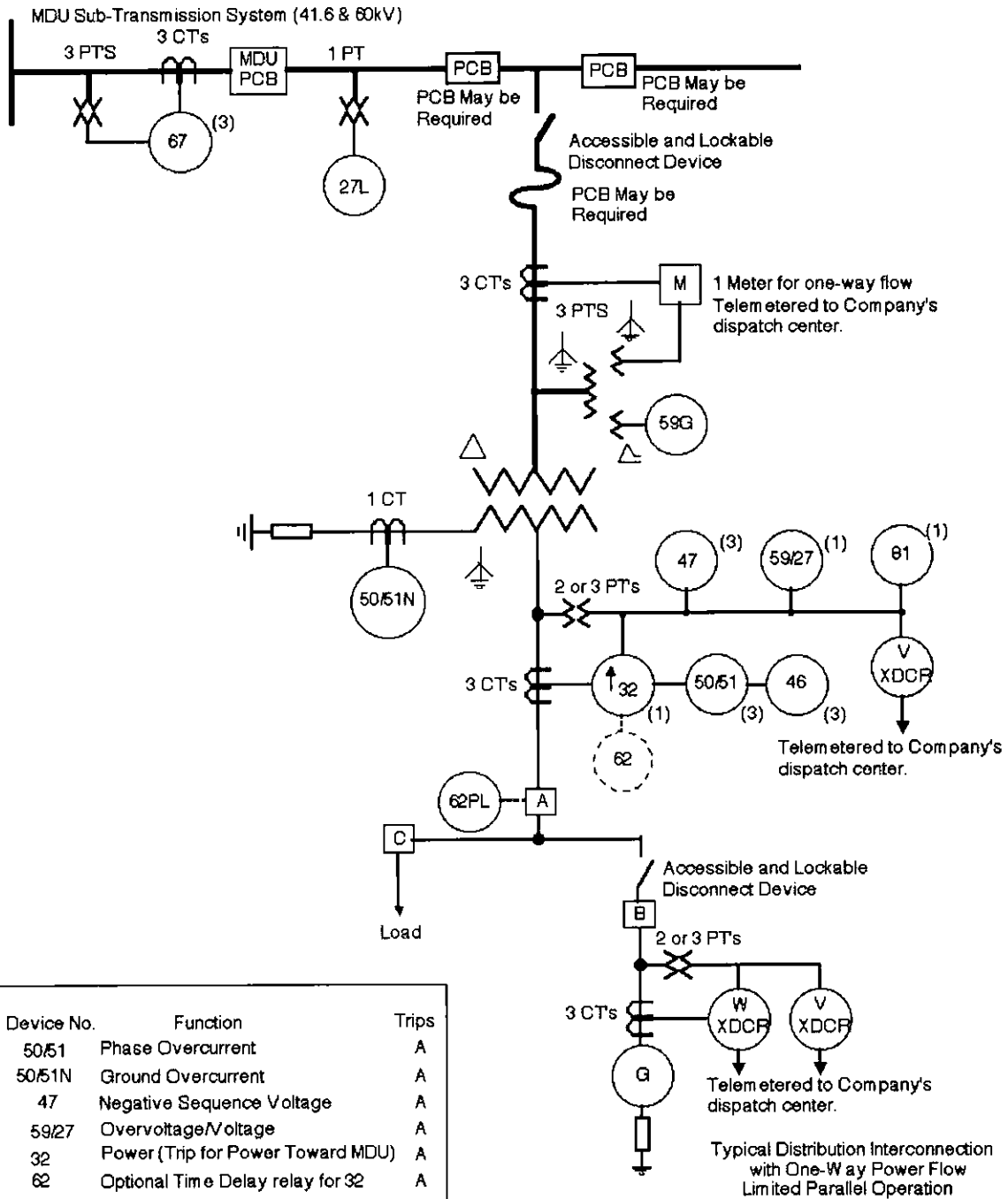

(1) (2) (3) Indicates Number of Phases Monitored

<b>MEDIUM GENERATOR BELOW 5000 KVA FIGURE 3B1</b>		
DATE: 8/10/07	<b>MONTANA-DAKOTA UTILITIES CO.</b>	DRAWING NO: 012591-3B1
APPROVED:		FILE NO: 51-1092-1
DATE	BY	REVISION



Device No.	Function	Trips
50/51	Phase Overcurrent	A
50/51N	Ground Overcurrent	A
47	Negative Sequence Voltage	A
59/27	Overvoltage/Voltage	A
32	Power (Trip for Power Toward MDU)	A
62	Optional Time Delay relay for 32	A
46	Negative sequence overcurrent	A
61	Overfrequency and Underfrequency	A
59G	Ground-Overvoltage	A
62PL	Parallel Limit Timer	A
27L	Undervoltage (Reclose Supv)	
67	Directional Overcurrent	

(1)(2)(3) Indicates Number of Phases Monitored

		<b>MEDIUM GENERATOR</b> <b>FIGURE 3C</b>		
		<b>MONTANA-DAKOTA</b> <b>UTILITIES CO.</b>		
DATE:	12/8/89	APPROVED:		DRAWING NO.:
		12/30/92 chr	Add Gen Ground	012591-3C
		1/25/93 J.V.E.L.L.	ADD FILE NUMBERS	FILE NO.:
		DATE	BY	REVISION
				51-1033

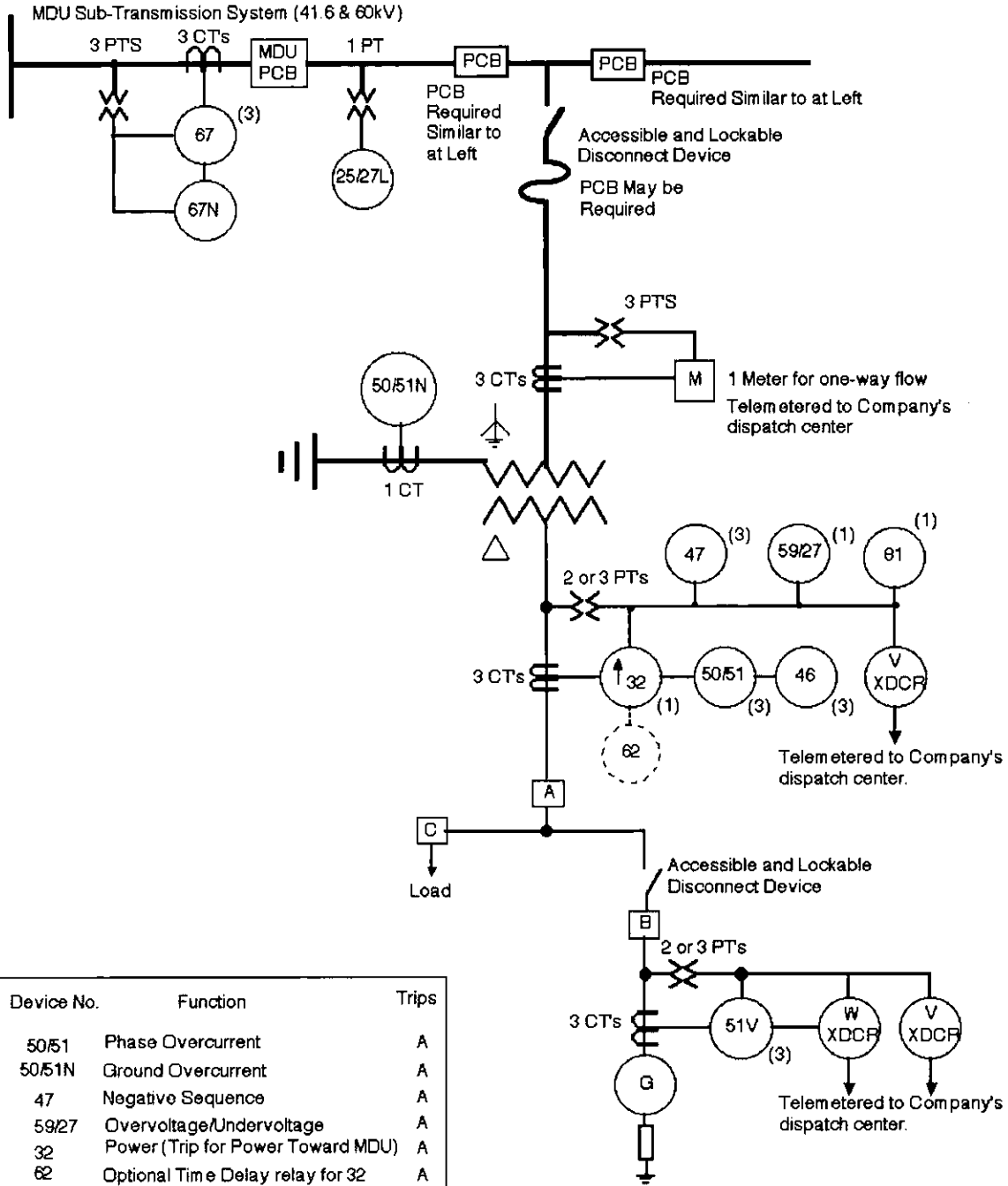

Typical Distribution Interconnection with One-Way Power Flow

Device No.	Function	Trips
50/51	Phase Overcurrent	A
50/51N	Ground Overcurrent	A
47	Negative Sequence	A
59/27	Overtoltage/Undervoltage	A
32	Power (Trip for Power Toward MDU)	A
62	Optional Time Delay relay for 32	A
46	Negative sequence overcurrent	A
81	Overfrequency and Underfrequency	A
51V	Voltage Supervised Overcurrent	B
25/27L	Synch-Check/Line Voltage Check	
67	Directional Overcurrent	
67N	Directional Ground Overcurrent	

(1)(2)(3) Indicates Number of Phases Monitored

MEDIUM GENERATOR		
FIGURE 3D		
DATE: 12/8/89	<b>MONTANA-DAKOTA UTILITIES CO.</b>	DRAWING NO: 012591-3D
APPROVED:	11/06/94 dhr Add 51V	FILE NO: <b>51-1034</b>
	8/10/03 dhr Separate Voltage Functions	
	DATE BY REVISION	

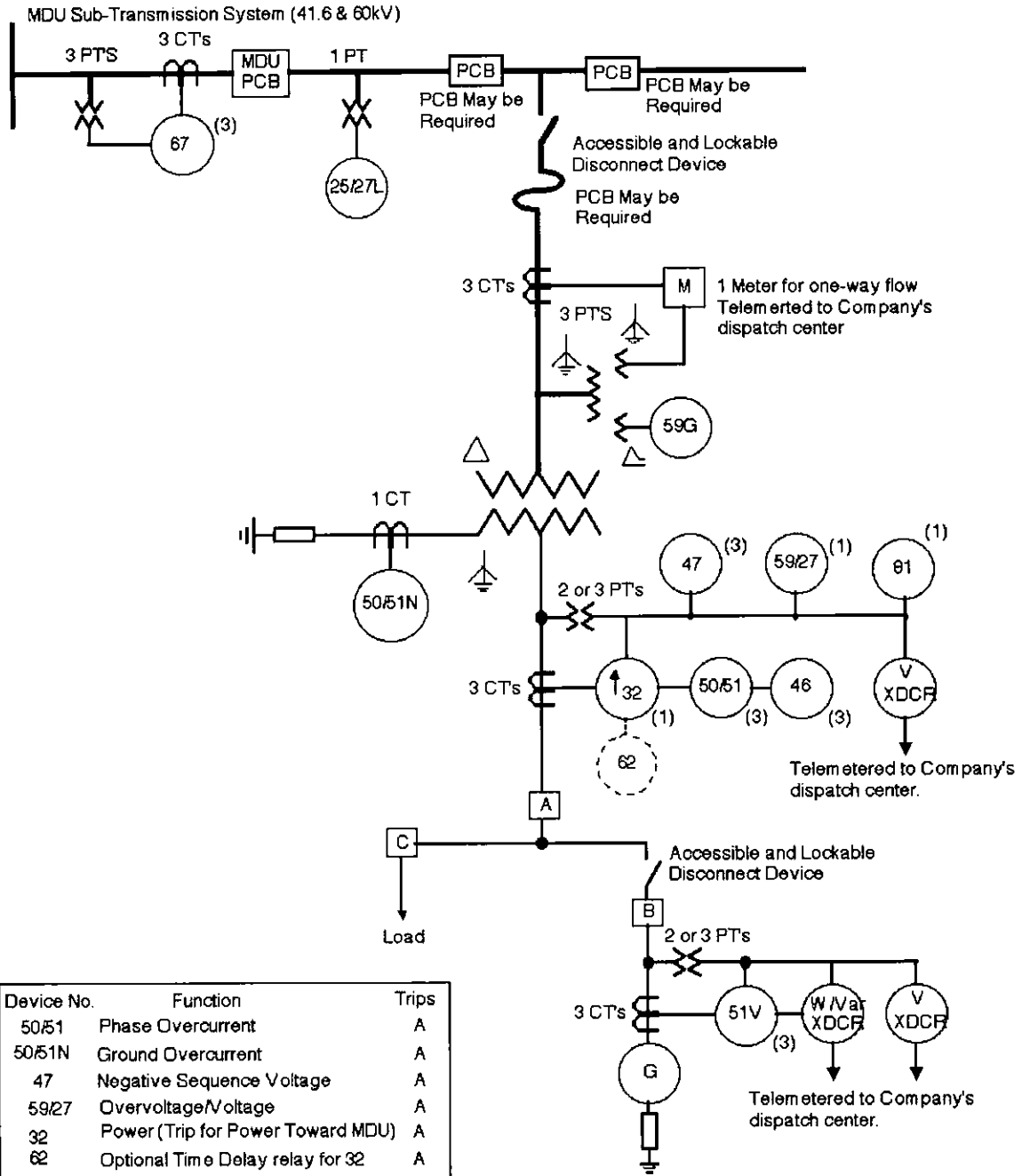

Device No.	Function	Trips
50/51	Phase Overcurrent	A
50/51N	Ground Overcurrent	A
47	Negative Sequence Voltage	A
59/27	Overtoltage/Voltage	A
32	Power (Trip for Power Toward MDU)	A
62	Optional Time Delay relay for 32	A
46	Negative sequence overcurrent	A
81	Overfrequency and Underfrequency	A
59G	Ground-Overtoltage	A
51V	Voltage Supervised Overcurrent	B
25/27L	Synco-Check/Line Voltage Check	
67	Directional Overcurrent	

(1) (2) (3) Indicates Number of Phases Monitored

Typical Distribution Interconnection with One-Way Power Flow

		<b>MEDIUM GENERATOR</b> <b>FIGURE 3D1</b>			
		<b>MONTANA-DAKOTA</b> <b>UTILITIES CO.</b>			
DATE:	8/10/07	APPROVED:		DRAWING NO.	012591-3D1
				FILE NO.	51-1034-1
		DATE	BY	REVISION	

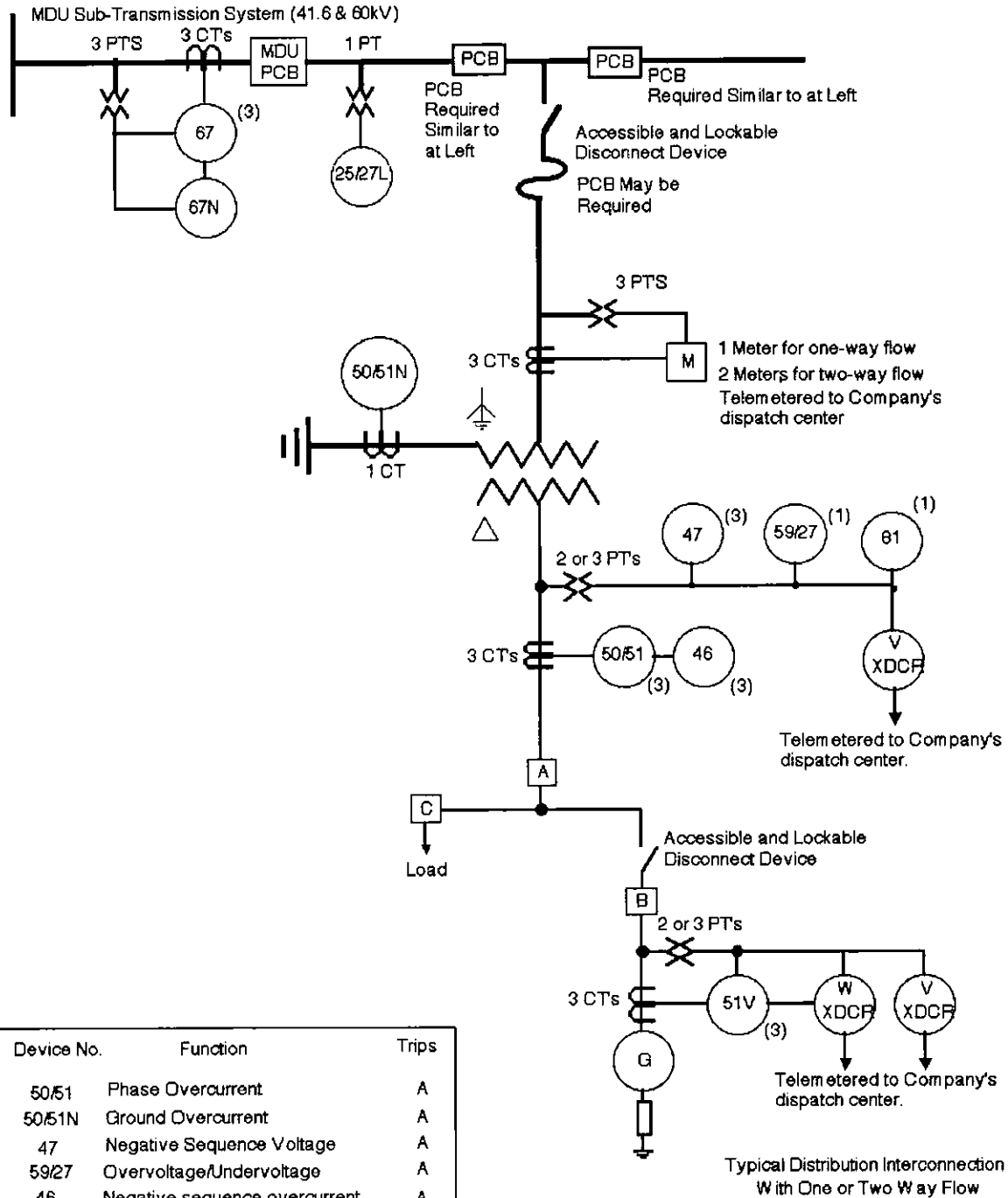

Device No.	Function	Trips
50/51	Phase Overcurrent	A
50/51N	Ground Overcurrent	A
47	Negative Sequence Voltage	A
59/27	Overvoltage/Undervoltage	A
46	Negative sequence overcurrent	A
81	Overfrequency and Underfrequency	A
51V	Voltage Supervised Overcurrent	B
67	Directional Overcurrent	
67N	Directional Ground Overcurrent	
25/27L	Sync-Check/Line Voltage Check	

(1)(2)(3) Indicates Number of Phases Monitored

	<b>MEDIUM GENERATOR</b>	
	<b>FIGURE 3E</b>	
DATE: 12/8/89	<b>MONTANA-DAKOTA UTILITIES CO.</b>	DRAWING NO: 012591-3E
APPROVED:	11/06/98 dhr 1/28/99 J VEIL	FILE NO: 51-1035
	Ground source note ADD NOTES	
	DATE BY REVISION	

MDU Sub-Transmission System (41.6 & 60kV)

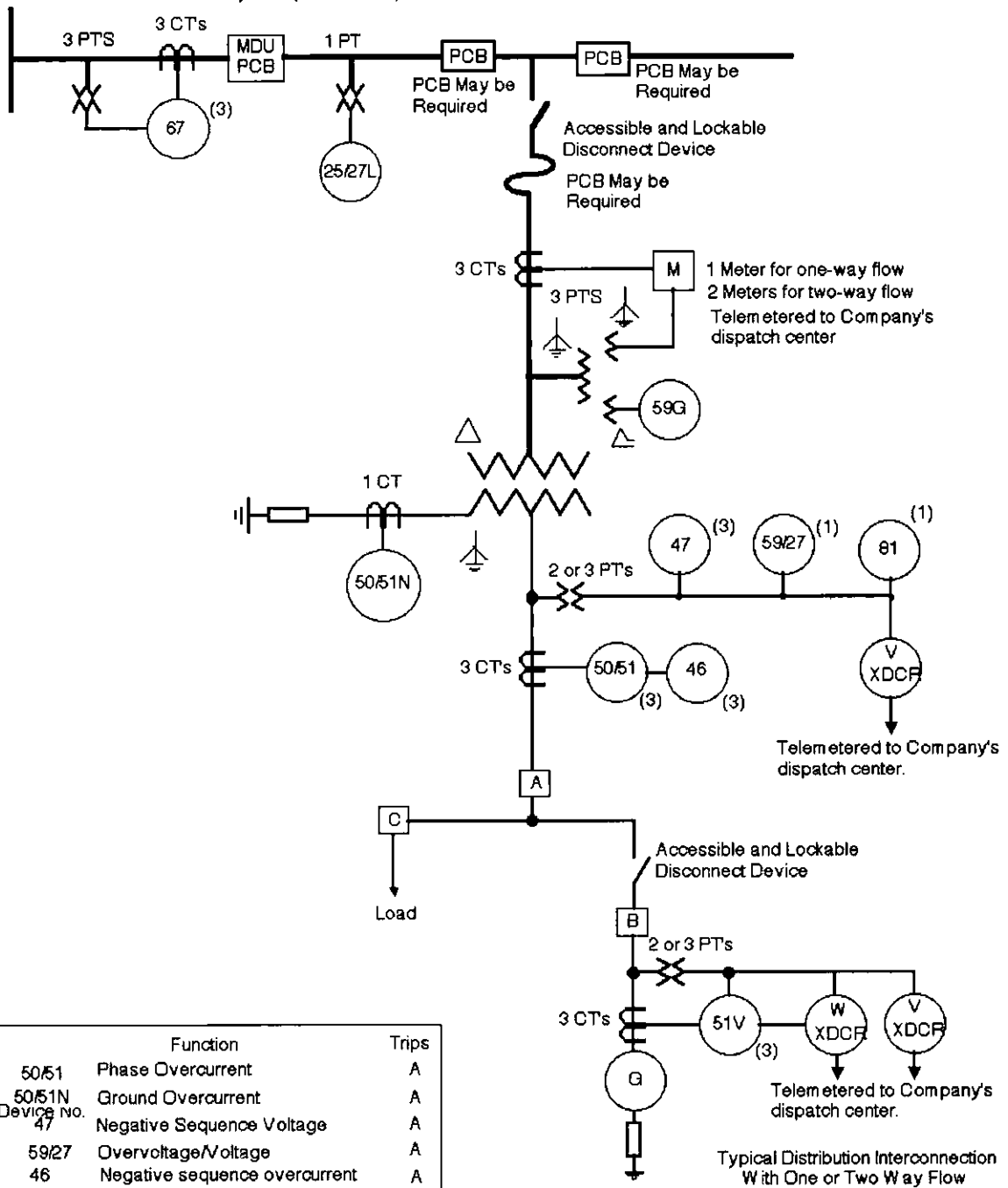

Device no.	Function	Trips
50/51	Phase Overcurrent	A
50/51N	Ground Overcurrent	A
47	Negative Sequence Voltage	A
59/27	Overvoltage/Voltage	A
46	Negative sequence overcurrent	A
81	Overfrequency and Underfrequency	A
59G	Ground-Overvoltage	A
51V	Voltage Supervised Overcurrent	B
25/27L	Sync-Check/Line Voltage Check	
67	Directional Overcurrent	

(1) (2) (3) Indicates Number of Phases Monitored

**MDU** MEDIUM GENERATOR  
FIGURE 3E1

DATE: 8/10/07	<b>MONTANA-DAKOTA UTILITIES CO.</b>	DRAWING NO: 012591-3E1
APPROVED:		FILE NO: 51-1035-1
DATE	BY	REVISION



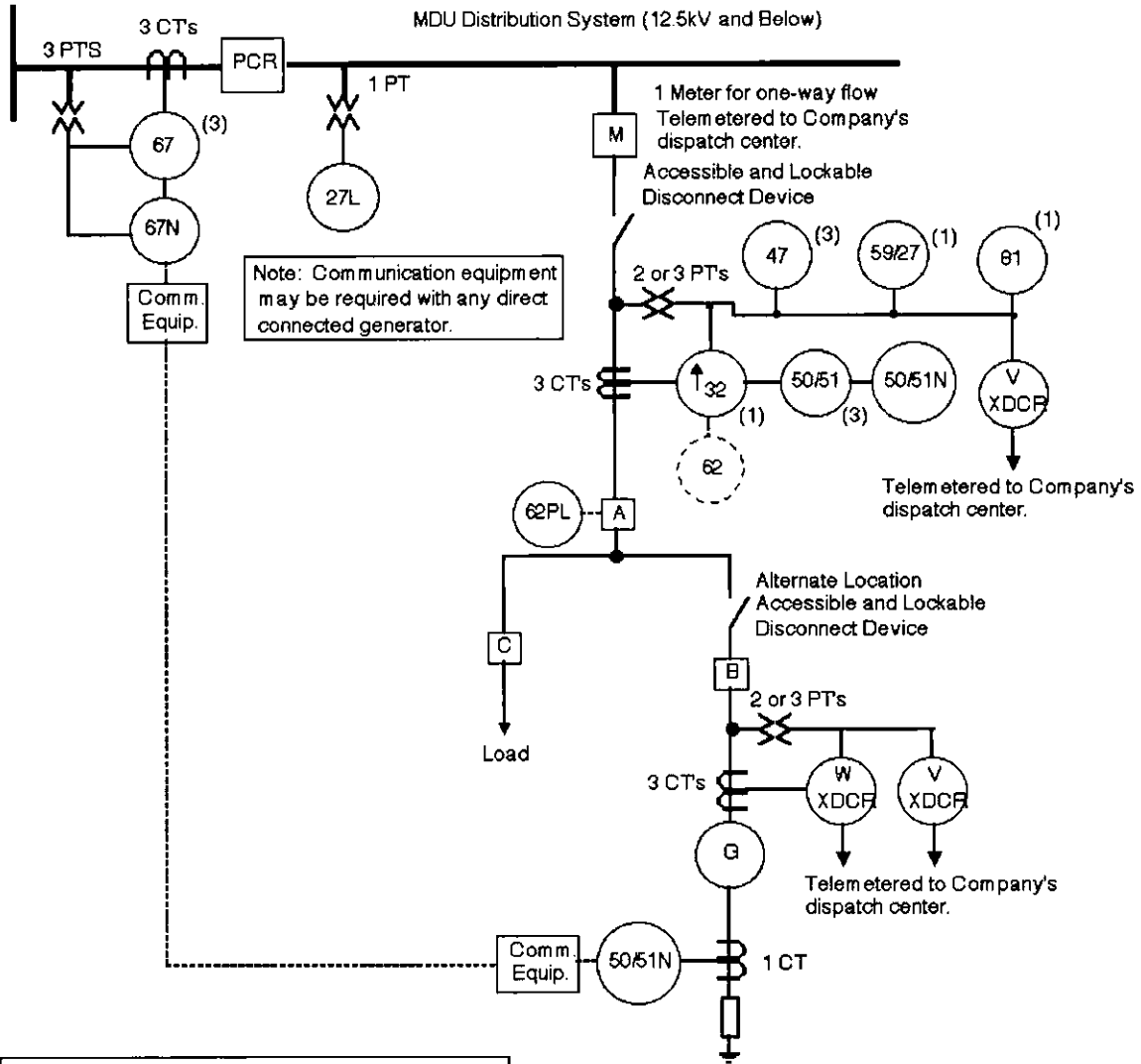

Device No.	Function	Trips
50/51	Phase Overcurrent	A
50/51N	Ground Overcurrent	A
47	Negative Sequence Voltage	A
59/27	Overvoltage/Undervoltage	A
32	Power (Trip for Power Toward MDU)	A
62	Optional Time Delay relay for 32	A
81	Overfrequency and Underfrequency	A
62PL	Parallel Limit Timer	A
27L	Undervoltage	
67	Directional Overcurrent	
67N	Directional Ground Overcurrent	

(1)(2)(3) Indicates Number of Phases Monitored

Typical Distribution Interconnection with One-Way Power Flow  
Limited Parallel Operation

	MEDIUM GENERATOR BELOW 5000 KVA FIGURE 3F		
	DATE: 12/8/89	<b>MONTANA-DAKOTA UTILITIES CO.</b>	
APPROVED:	8/10/07 dhr	Separate Voltage Functions	DRAWING NO: 012591-3F
	1/25/91 J.VEIL	ADD FILE NUMBERS	FILE NO: 51-1036
	DATE	BY	REVISION

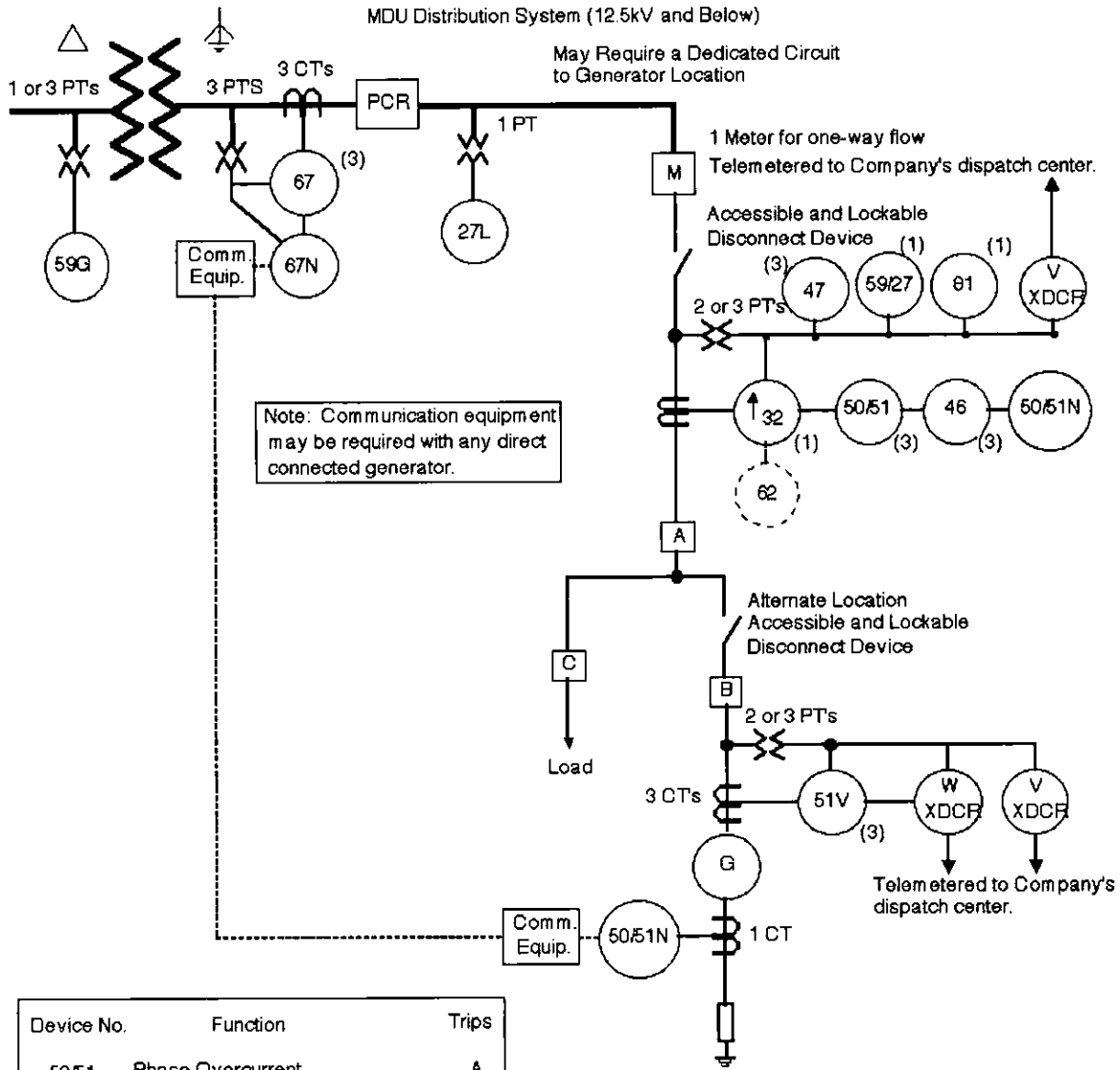

Device No.	Function	Trips
50/51	Phase Overcurrent	A
50/51N	Ground Overcurrent	A
47	Negative Sequence	A
59/27	Overtvoltage/Undervoltage	A
32	Power (Trip for Power Toward MDU)	A
62	Optional Time Delay relay for 32	A
46	Negative sequence overcurrent	A
81	Overfrequency and Underfrequency	A
51V	Voltage Supervised Overcurrent	B
27L	Undervoltage	
67	Directional Overcurrent	
67N	Directional Ground Overcurrent	
59G	Ground-Overtvoltage	

(1)(2)(3) Indicates Number of Phases Monitored

Typical Distribution Interconnection with One-Way Power Flow

	<b>MEDIUM GENERATOR BELOW 5000 KVA FIGURE 3G</b>	
DATE: 12/8/89	<b>MONTANA-DAKOTA UTILITIES CO.</b>	DRAWING NO: 012591-36
APPROVED:	11/06/98 dhr Add 51V 8/10/07 dhr Separate Voltage Functions	FILE NO: 51-1037
	DATE BY REVISION	

MDU Distribution System (12.5kV and Below)

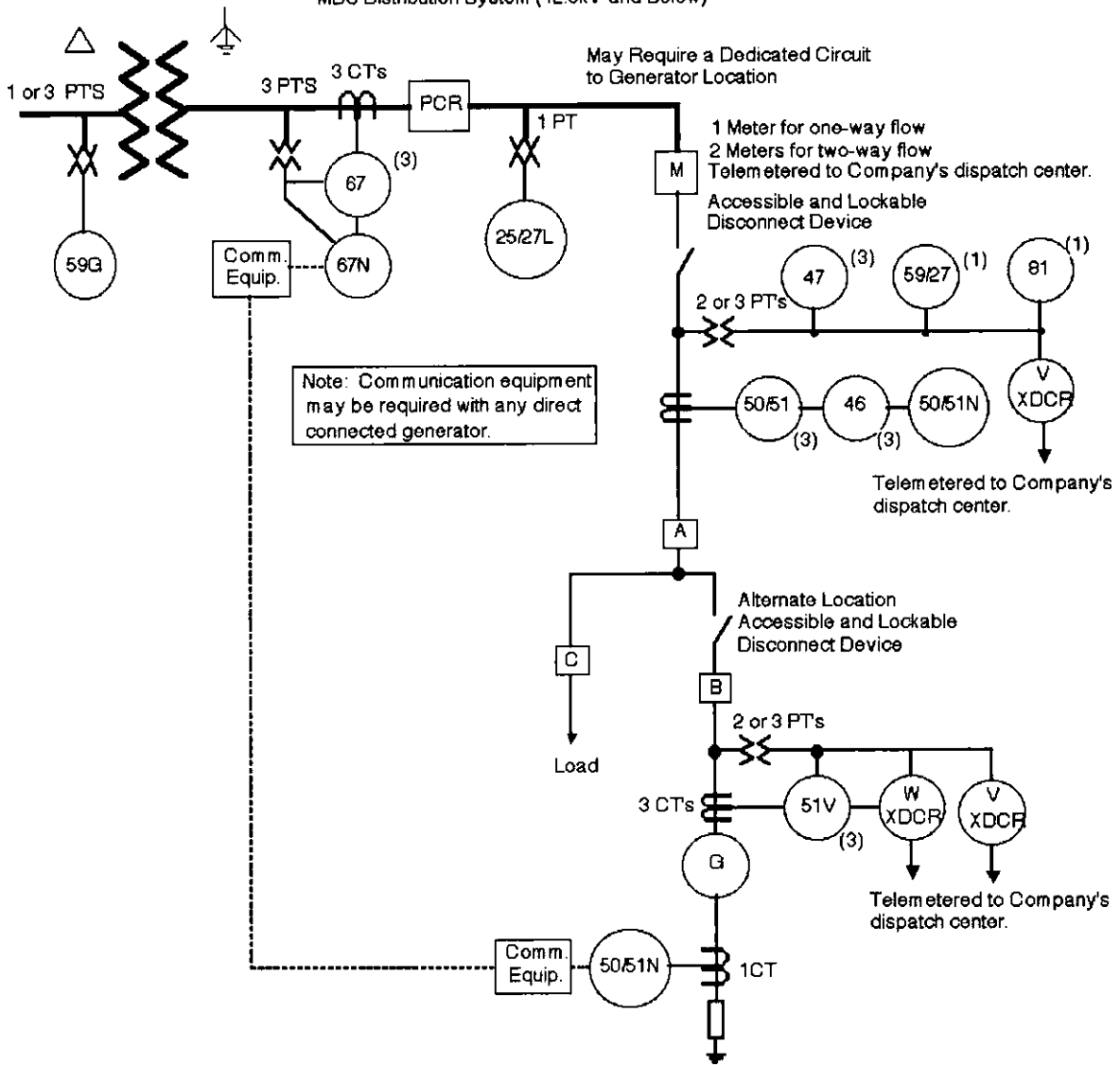



Device No.	Function	Trips
50/51	Phase Overcurrent	A
50/51N	Ground Overcurrent	A
47	Negative Sequence Voltage	A
59/27	Overtoltage/Undervoltage	A
46	Negative sequence overcurrent	A
81	Overfrequency and Underfrequency	A
51V	Voltage Supervised Overcurrent	B
25/27L	Sync-Check/Line Voltage Check	
67	Directional Overcurrent	
67N	Directional Ground Overcurrent	
59G	Ground-Overtoltage	

(1)(2)(3) Indicates Number of Phases Monitored

Typical Distribution Interconnection  
With One or Two Way Flow

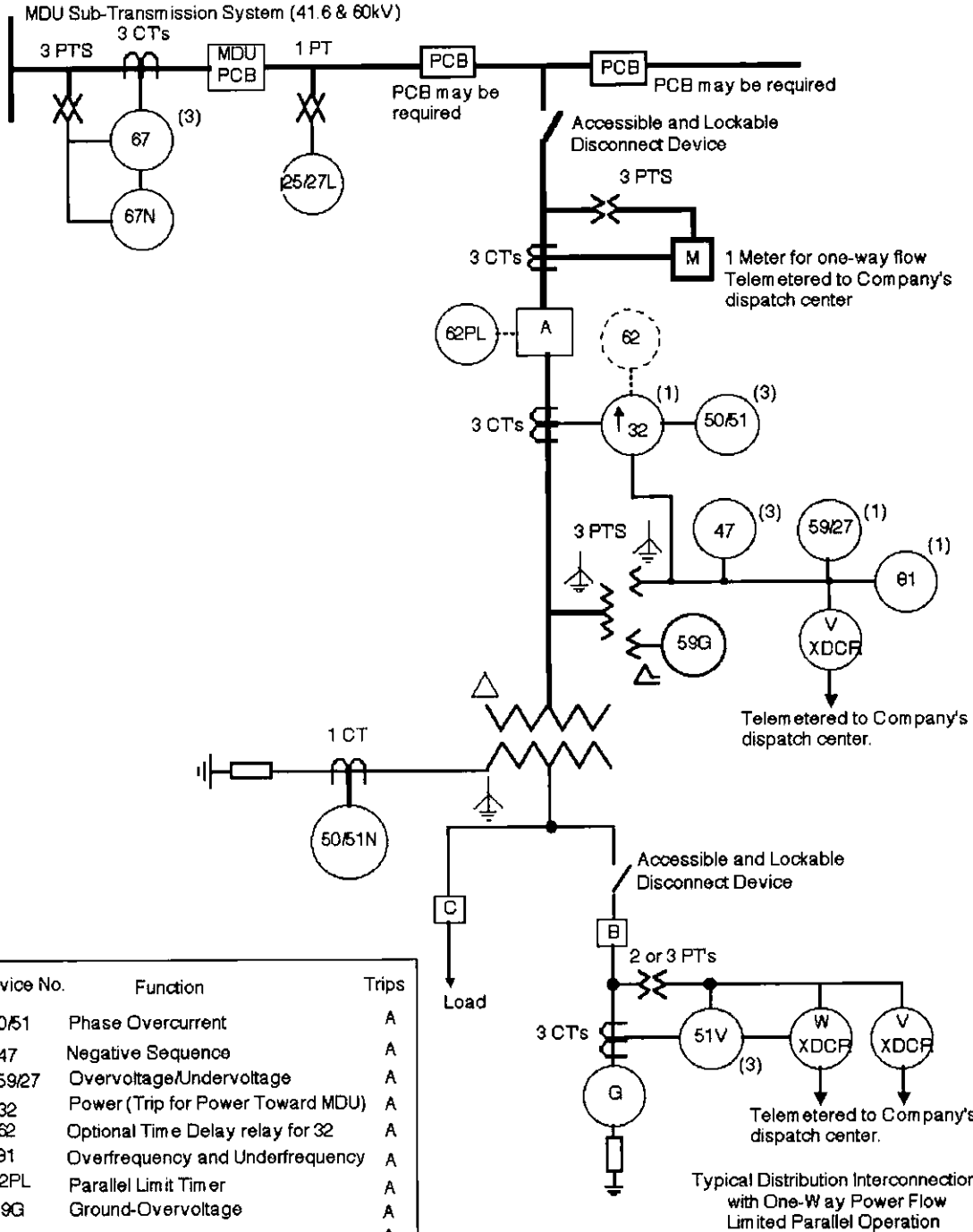
	MEDIUM GENERATOR BELOW 5000 KVA FIGURE 3H		
	DATE: 12/8/89	<b>MONTANA-DAKOTA                  UTILITIES CO.</b>	
APPROVED: 1/28/91 J.YEIL 1/25/91 J.YEIL	ADD NOTES ADD FILE NUMBERS	FILE NO: 51-1038	
DATE	BY	REVISION	



	<b>LARGE GENERATOR</b> <b>FIGURE 4</b>										
	<b>MONTANA-DAKOTA UTILITIES CO.</b>										
DATE: 12/8/89	APPROVED: <table border="1" style="display: inline-table; vertical-align: middle;"> <tr> <td>10/6/98 dhr</td> <td>Add 51V</td> </tr> <tr> <td>8/11/07 dhr</td> <td>Separate Voltage Functions</td> </tr> <tr> <td>DATE</td> <td>BY</td> </tr> <tr> <td></td> <td>REVISION</td> </tr> </table>		10/6/98 dhr	Add 51V	8/11/07 dhr	Separate Voltage Functions	DATE	BY		REVISION	DRAWING NO: 012591-4
10/6/98 dhr	Add 51V										
8/11/07 dhr	Separate Voltage Functions										
DATE	BY										
	REVISION										
			FILE NO: 51-1040								

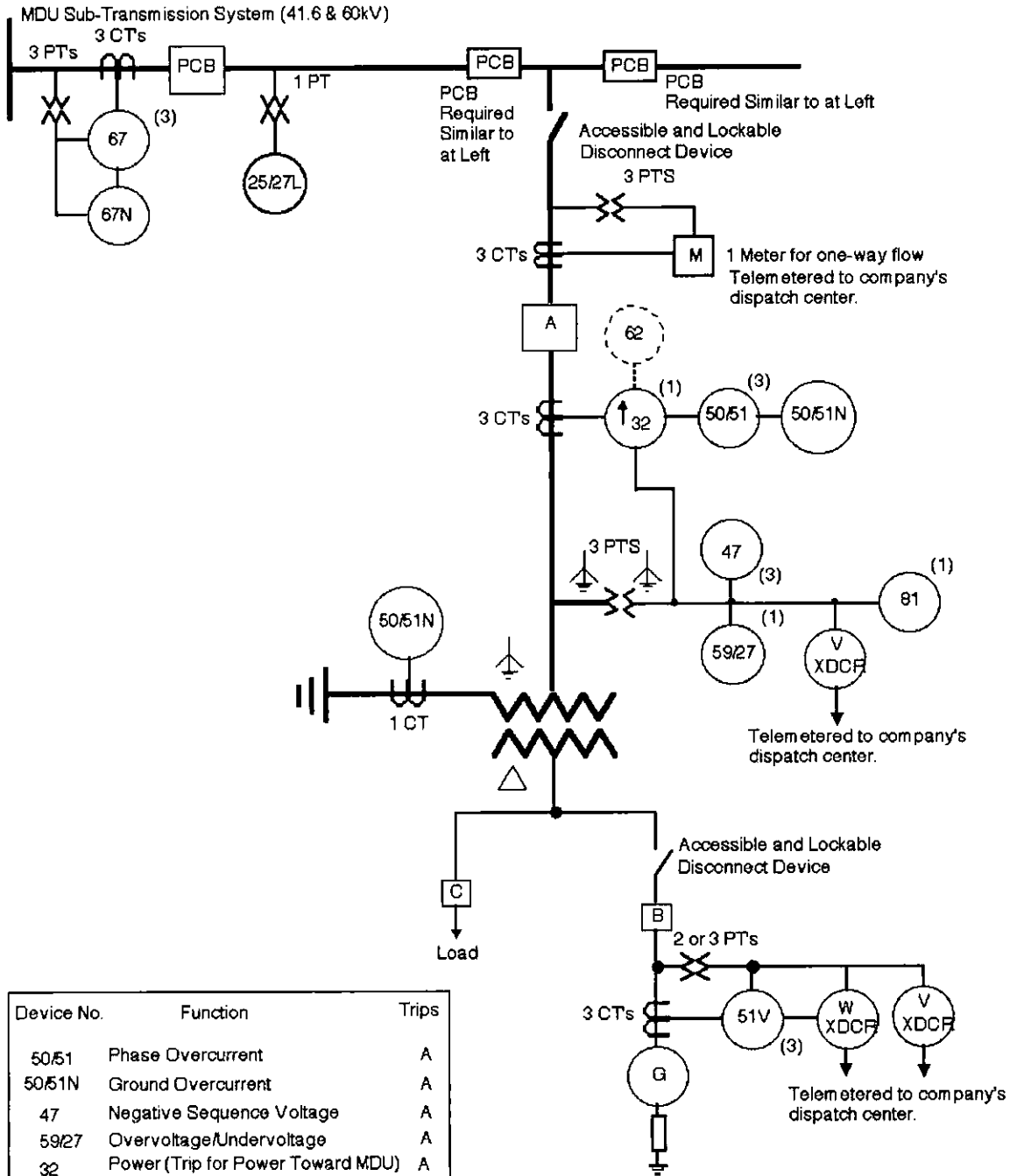

Device No.	Function	Trips
50/51	Phase Overcurrent	A
50/51N	Ground Overcurrent	A
47	Negative Sequence Voltage	A
59/27	Overtoltage/Undervoltage	A
32	Power (Trip for Power Toward MDU)	A
62	Optional Time Delay relay for 32	A
81	Overfrequency and Underfrequency	A
51V	Voltage Supervised Overcurrent	B
25/27L	Sync-Check/Line Voltage Check	
67	Directional Overcurrent	
67N	Directional Ground Overcurrent	

(1)(2)(3) Indicates Number of Phases Monitored

Typical Distribution Interconnection with One-Way Power Flow

		<b>LARGE GENERATOR</b> <b>FIGURE 4A</b>			
		<b>MONTANA-DAKOTA UTILITIES CO.</b>			
DATE:	12/8/89	APPROVED:	11/06/98 dhr Add 51V 8/11/07 dhr Separate Voltage Functions	DRAWING NO:	012591-4A
DATE:		BY:		REVISION:	
				FILE NO:	51-1041



Device No.	Function	Trips
50/51	Phase Overcurrent	A
47	Negative Sequence	A
59/27	Overvoltage/Undervoltage	A
32	Power (Trip for Power Toward MDU)	A
62	Optional Time Delay relay for 32	A
81	Overfrequency and Underfrequency	A
59G	Ground-Overvoltage	A
50/51N	Ground Overcurrent	A
51V	Voltage Supervised Overcurrent	B
25/27L	Sync-Check/Line Voltage Check	
67	Directional Overcurrent	
67N	Directional Ground Overcurrent	

(1)(2)(3) Indicates Number of Phases Monitored

Typical Distribution Interconnection with One-Way Power Flow

		<b>LARGE GENERATOR</b> <b>FIGURE 4A1</b>			
		<b>MONTANA-DAKOTA</b> <b>UTILITIES CO.</b>			
DATE:	8/11/07	<b>APPROVED:</b> _____ _____ DATE BY REVISION		DRAWING NO.:	012591-4A1
FILE NO.:	51-1041-1				

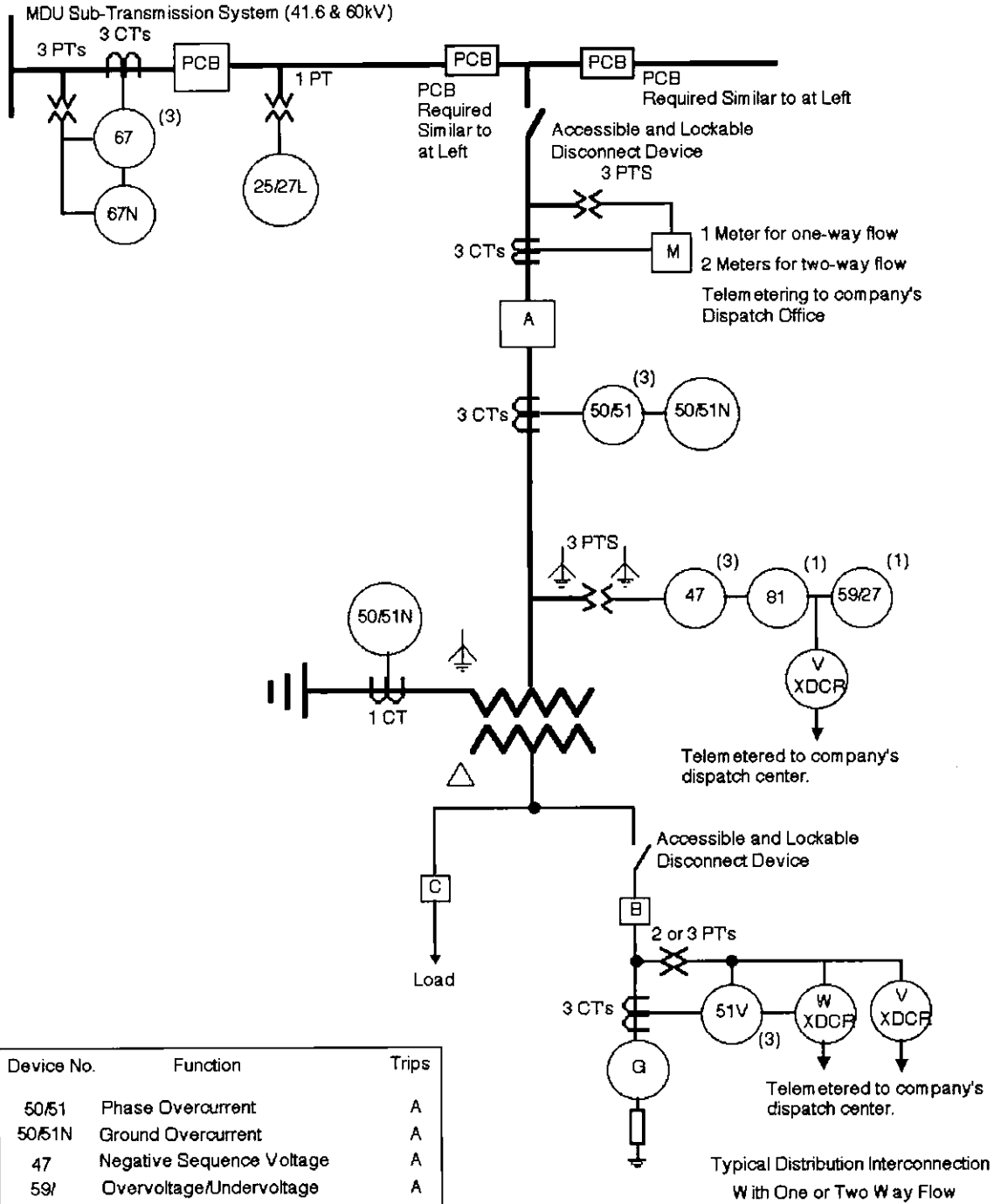

<b>MDU</b>		LARGE GENERATOR FIGURE 4B		
DATE: 12/8/89	<b>MONTANA-DAKOTA UTILITIES CO.</b>		DRAWING NO: 012591-4B	
APPROVED:	1/28/91 J.VEIL	ADD NOTES	FILE NO:	
	1/25/91 J.VEIL	ADD FILE NUMBERS	51-1042	
	DATE BY	REVISION		

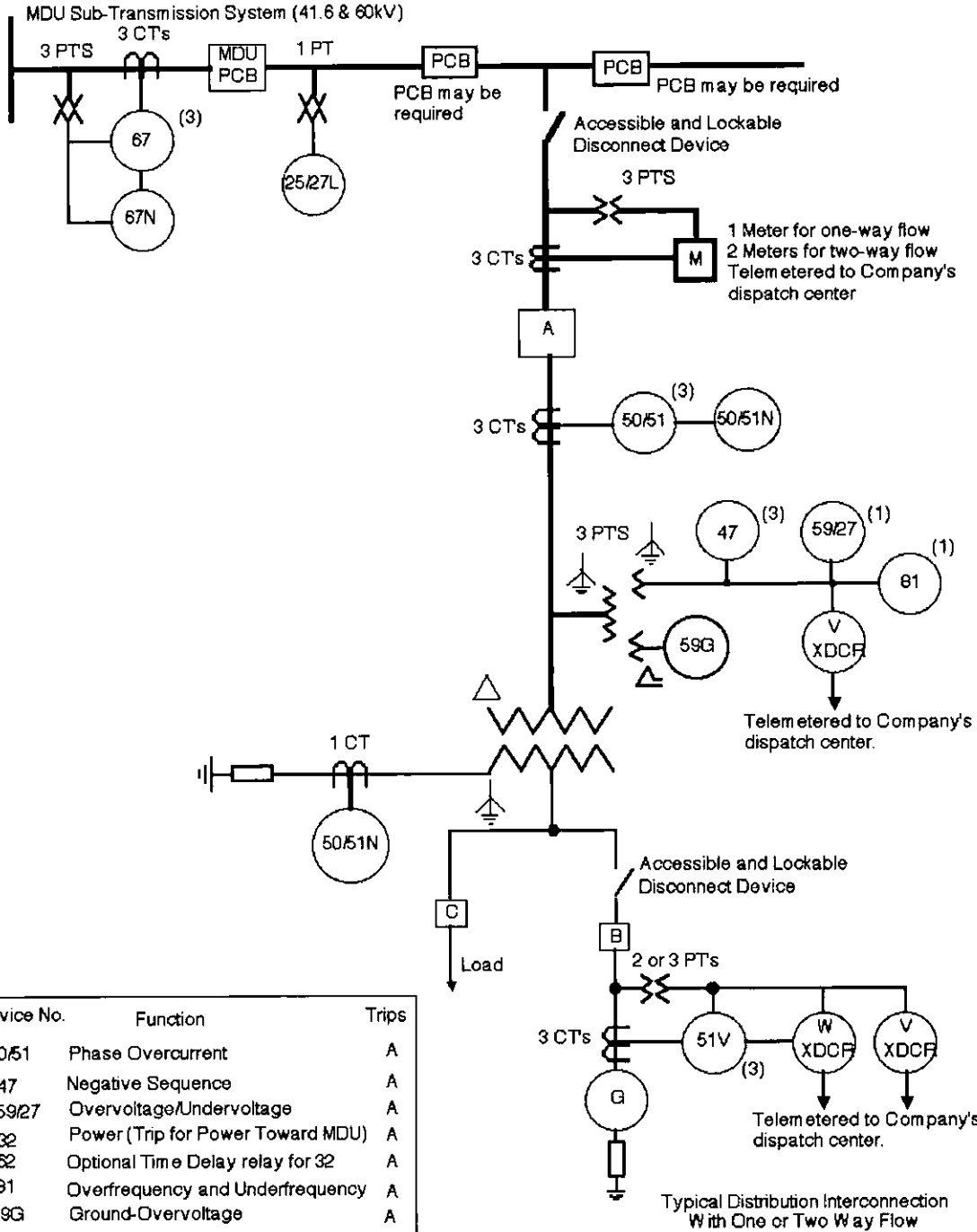

		<b>LARGE GENERATOR</b> <b>FIGURE 4B1</b>		
		<b>MONTANA-DAKOTA</b> <b>UTILITIES CO.</b>		
DATE:	8/11/07	<b>APPROVED:</b>		DRAWING NO:
				012591-4B1
DATE	BY	REVISION	FILE NO:	51-1042-1



## APPENDIX "B"

## MONTANA-DAKOTA UTILITIES CO.

## INTERCONNECTION EQUIPMENT AND GENERATOR DATA INFORMATION FORM

This information form may be used to supply Company with interconnection equipment and generator data required in Section II C3 and Section VII A5 of GUIDELINE FOR INTERCONNECTION REQUIREMENTS AND PARALLEL OPERATION OF CUSTOMER-OWNED GENERATION. The information will be used to make an accurate model of Customer's installation on Company's system so detailed interconnection studies may be made.

If data submitted is based on estimated quantities, additional or revised data must be submitted when the information becomes available. This subsequent data may be supplied by using this form or by letter or email transmittal of data, manufacturer documents or copies of certified test reports.

## OWNER / APPLICANT INFORMATION:

Name: \_\_\_\_\_.  
 Mailing Address: \_\_\_\_\_.  
 City: \_\_\_\_\_ State: \_\_\_\_\_ Zip: \_\_\_\_\_.  
 Phone Number: \_\_\_\_\_ Representative: \_\_\_\_\_.

## PROJECT DESIGN / ENGINEERING (ARCHITECT) (as applicable):

Company: \_\_\_\_\_.  
 Mailing Address: \_\_\_\_\_.  
 City: \_\_\_\_\_ State: \_\_\_\_\_ Zip: \_\_\_\_\_.  
 Phone Number: \_\_\_\_\_ Representative: \_\_\_\_\_.

## ELECTRICAL CONTRACTOR (as applicable);

Company: \_\_\_\_\_.  
 Mailing Address: \_\_\_\_\_.  
 City: \_\_\_\_\_ State: \_\_\_\_\_ Zip: \_\_\_\_\_.  
 Phone Number: \_\_\_\_\_ Representative: \_\_\_\_\_.

Please complete all the following applicable items. Copy the following pages as required for additional equipment.

SYNCHRONOUS GENERATOR DATA:

Unit Number: \_\_\_\_\_ Total number of units on site: \_\_\_\_\_ .  
 Manufacturer: \_\_\_\_\_ .  
 Type: \_\_\_\_\_ Date of manufacture: \_\_\_\_\_ .  
 Serial Number: \_\_\_\_\_ .  
 Phases: Single \_\_\_\_\_ Three \_\_\_\_\_ R.P.M.: \_\_\_\_\_ Frequency (Hz): \_\_\_\_\_ .  
 Rated Output: \_\_\_\_\_ Kilowatt \_\_\_\_\_ Kilovolt-Ampere  
 Rated Power Factor (%): \_\_\_\_\_ Rated Voltage (Volts): \_\_\_\_\_ .  
 Rated Amperes: \_\_\_\_\_ Motoring Power (kW): \_\_\_\_\_ .  
 Type Excitation: \_\_\_\_\_ .  
 Field Volts: \_\_\_\_\_ Field Amps: \_\_\_\_\_ .  
 Stator Resistance: \_\_\_\_\_ ohms at \_\_\_\_\_ degrees C  
 Field Resistance: \_\_\_\_\_ ohms at \_\_\_\_\_ degrees C  
 Synchronous Direct Axis Reactance (Xd): \_\_\_\_\_ % on \_\_\_\_\_ kVA base  
 Synchronous Quadrature Axis Reactance (Xq): \_\_\_\_\_ % on \_\_\_\_\_ kVA base  
 Transient Saturated Reactance (X'd): \_\_\_\_\_ % on \_\_\_\_\_ kVA base  
 Subtransient Direct Axis Reactance (X''d): \_\_\_\_\_ % on \_\_\_\_\_ kVA base  
 Subtransient Quadrature Axis Reactance (X''q): \_\_\_\_\_ % on \_\_\_\_\_ kVA base  
 Negative Sequence Reactance (X2): \_\_\_\_\_ % on \_\_\_\_\_ kVA base  
 Zero Sequence Reactance (Xo): \_\_\_\_\_ % on \_\_\_\_\_ kVA base  
 I<sub>2</sub><sup>2</sup>t or K (heating time constant): \_\_\_\_\_ .  
 Type Grounding: \_\_\_\_\_ .  
 Neutral Grounding Transformer Rating (if applicable): \_\_\_\_\_ .  
     kVA base rating: \_\_\_\_\_ Per Cent Impedance: \_\_\_\_\_ .  
     Primary Voltage: \_\_\_\_\_ Secondary Voltage: \_\_\_\_\_ .  
 Neutral Grounding Resistor Rating (if applicable): \_\_\_\_\_ ohms  
     Rated Amps: \_\_\_\_\_ Rated Voltage: \_\_\_\_\_ .  
 Additional Information: \_\_\_\_\_ .  
 \_\_\_\_\_ .  
 \_\_\_\_\_ .  
 \_\_\_\_\_ .

## INDUCTION GENERATOR DATA:

Field Volts: \_\_\_\_\_ Field Amps: \_\_\_\_\_  
 Motoring Power (kW): \_\_\_\_\_  
 Rotor Resistance (Rr): \_\_\_\_\_ ohms Rotor Reactance (Xr): \_\_\_\_\_ ohms  
 Stator Resistance (Rs): \_\_\_\_\_ ohms Stator Reactance (Xs): \_\_\_\_\_ ohms  
 Total Rotating Inertia, H: \_\_\_\_\_ Per Unit on kVA Base  
 Magnetizing Reactance (Xm): \_\_\_\_\_ ohms  
 Short Circuit Reactance (Xd''): \_\_\_\_\_ ohms  
 Design Letter: \_\_\_\_\_ Frame Size: \_\_\_\_\_  
 Exciting Current: \_\_\_\_\_ Temp Rise (deg C): \_\_\_\_\_  
 Reactive Power Required: \_\_\_\_\_ Vars (no load),  
 \_\_\_\_\_ Vars (full load)  
 Capacitive Compensation (if applicable): \_\_\_\_\_  
 CVars: \_\_\_\_\_ Voltage Rating: \_\_\_\_\_  
 Power Factor Range of Generator (if applicable): \_\_\_\_\_  
 Neutral Grounding Resistor Rating (if applicable): \_\_\_\_\_ ohms  
 Rated Amps: \_\_\_\_\_ Rated Voltage: \_\_\_\_\_  
 $I_2^2t$  or K (heating time constant): \_\_\_\_\_  
 Additional Information: \_\_\_\_\_  
 \_\_\_\_\_  
 \_\_\_\_\_  
 \_\_\_\_\_

Note: Reactive Power Required is the amount required without the Capacitive Compensation in service.

## PRIME MOVER (Complete all applicable items):

Unit Number: \_\_\_\_\_ Type: \_\_\_\_\_  
 Manufacturer: \_\_\_\_\_  
 Serial Number: \_\_\_\_\_  
 H.P. Rated: \_\_\_\_\_ H.P. Max.: \_\_\_\_\_  
 Inertia Constant: \_\_\_\_\_ lb.-ft  
 Energy Source (diesel, steam, wind, etc.): \_\_\_\_\_  
 Additional Information: \_\_\_\_\_  
 \_\_\_\_\_  
 \_\_\_\_\_  
 \_\_\_\_\_

## ADDITIONAL DATA FOR INSTALLATIONS CLASSIFIED AS LARGE:

Governor: Data required to model all significant responses to frequency disturbances. The response shall include effects of all significant components of the entire installation (i.e. prime mover, steam flow lags, percent split in power between multiple stages, etc.).

Exciter: Data required for modeling dynamic exciter response.

Rotating Mass: Data required for modeling dynamic inertia. Include all significant components contributing to the rotating mass (i.e. prime mover, generator, etc.).

GENERATOR TRANSFORMER (Complete all applicable items):

Generator Unit Number: \_\_\_\_\_ Date of Manufacture: \_\_\_\_\_ .  
 Manufacturer: \_\_\_\_\_ .  
 Serial Number: \_\_\_\_\_ .  
 High Voltage: \_\_\_\_\_ kV, Connection: Delta \_\_\_ Wye \_\_\_ ,  
 Neutral Solidly grounded?: Yes \_\_\_ No \_\_\_ .  
 Low Voltage: \_\_\_\_\_ kV, Connection: Delta \_\_\_ Wye \_\_\_ ,  
 Neutral Solidly grounded?: Yes \_\_\_ No \_\_\_ .  
 Base Rating: \_\_\_\_\_ kVA Maximum Rating: \_\_\_\_\_ kVA  
 Transformer Impedance (Z): \_\_\_\_\_ % on \_\_\_\_\_ kVA base  
 Transformer Resistance (R): \_\_\_\_\_ % on \_\_\_\_\_ kVA base  
 Transformer Reactance (X): \_\_\_\_\_ % on \_\_\_\_\_ kVA base  
 Neutral Grounding Resistor Rating (if applicable): \_\_\_\_\_ ohms  
 Rated Amps: \_\_\_\_\_ Rated Voltage: \_\_\_\_\_ .  
 Fuse Manufacturer: \_\_\_\_\_ Fuse Type: \_\_\_\_\_ .  
 Fuse Size: \_\_\_\_\_ Fuse Speed: \_\_\_\_\_ .  
 Additional Information: \_\_\_\_\_ .  
 \_\_\_\_\_ .  
 \_\_\_\_\_ .  
 \_\_\_\_\_ .

Note: If applicable attach copies of fuse manufacturer's Minimum Melt & Total Clearing Time-Current Curves

INVERTER DATA (if applicable):

Manufacturer: \_\_\_\_\_ Model: \_\_\_\_\_ .  
 Rated Power Factor (%): \_\_\_\_\_ Rated Volts: \_\_\_\_\_ Rated Amps: \_\_\_\_\_ .  
 Inverter Type (ferroresonant, step, pulse-width modulation, etc.): \_\_\_\_\_ .  
 \_\_\_\_\_ .  
 Type Commutation: Forced \_\_\_ Line \_\_\_ .  
 Harmonic Distortion: Maximum Single Harmonic (%): \_\_\_\_\_ .  
 Maximum Total Harmonic (%): \_\_\_\_\_ .  
 Additional Information: \_\_\_\_\_ .  
 \_\_\_\_\_ .  
 \_\_\_\_\_ .  
 \_\_\_\_\_ .

Note: Attach all available calculations, test reports, distortion analyzer reports, and oscillographic prints showing inverter output voltage and current waveforms.

## POWER CIRCUIT BREAKER:

Manufacturer: \_\_\_\_\_ Model: \_\_\_\_\_  
 Rated Voltage: \_\_\_\_\_ volts Rated Amps: \_\_\_\_\_  
 Interrupting Rating (symmetrical amps): \_\_\_\_\_  
 Interrupting Rating (asymmetrical amps): \_\_\_\_\_  
 Interrupting Medium / Insulating Medium (air, vacuum, SF6, oil, etc.): \_\_\_\_\_  
 BIL Rating: \_\_\_\_\_ kV  
 Control Voltage (Closing): \_\_\_\_\_ volts AC \_\_\_\_\_ DC \_\_\_\_\_  
 Control Voltage (Tripping): \_\_\_\_\_ volts AC \_\_\_\_\_ DC \_\_\_\_\_  
 Close Energy (spring, motor, hydraulic, pneumatic, etc.): \_\_\_\_\_  
 Trip Energy (spring, motor, hydraulic, pneumatic, etc.): \_\_\_\_\_  
 Bushing Current Transformers: \_\_\_\_\_  
     Indicate All Available Ratios: \_\_\_\_\_  
     Relay Accuracy Class: \_\_\_\_\_

## TRANSFER SWITCH INFORMATION:

Manufacturer: \_\_\_\_\_  
 Model: \_\_\_\_\_  
 Catalog Number: \_\_\_\_\_  
 Instruction Book Number: \_\_\_\_\_  
 Rated Voltage: \_\_\_\_\_ volts Rated Amps: \_\_\_\_\_  
 Is Normal Function "Closed Transition Transfer": Yes \_\_\_\_\_ No \_\_\_\_\_  
     Other (describe): \_\_\_\_\_  
 Is Closed Transition Time: Adjustable \_\_\_\_\_ Not Adjustable \_\_\_\_\_  
 Closed transition time range, min. & max.: \_\_\_\_\_  
 Transfer Switch Includes "By-Pass Switch": Yes \_\_\_\_\_ No \_\_\_\_\_

## CURRENT TRANSFORMERS (Per Bank):

Circuit Location Description: \_\_\_\_\_  
 Manufacturer: \_\_\_\_\_ Model: \_\_\_\_\_  
 Serial Numbers (all units): \_\_\_\_\_  
 Indicate All Available Ratios: \_\_\_\_\_  
 Accuracy Class: \_\_\_\_\_ Burden: \_\_\_\_\_

## POTENTIAL TRANSFORMERS (Per Bank):

Circuit Location Description: \_\_\_\_\_  
 Manufacturer: \_\_\_\_\_ Model: \_\_\_\_\_  
 Serial Numbers (all units): \_\_\_\_\_  
 Indicate All Available Ratios: \_\_\_\_\_  
 Accuracy Class: \_\_\_\_\_ Thermal Rating: \_\_\_\_\_  
 Burden: \_\_\_\_\_

RELAY INFORMATION (For Each Relay):

Manufacturer: \_\_\_\_\_ .  
 Model: \_\_\_\_\_ .  
 Catalog Number: \_\_\_\_\_ .  
 Function: \_\_\_\_\_ .  
 Instruction Book Number: \_\_\_\_\_ .  
 Internal Schematic Drawing Number: \_\_\_\_\_ .  
 External Schematic Drawing Number: \_\_\_\_\_ .

MISCELLANEOUS (Use this area and any additional sheets for applicable notes and comments):

\_\_\_\_\_ .  
 \_\_\_\_\_ .  
 \_\_\_\_\_ .  
 \_\_\_\_\_ .  
 \_\_\_\_\_ .  
 \_\_\_\_\_ .  
 \_\_\_\_\_ .  
 \_\_\_\_\_ .  
 \_\_\_\_\_ .  
 \_\_\_\_\_ .  
 \_\_\_\_\_ .  
 \_\_\_\_\_ .  
 \_\_\_\_\_ .  
 \_\_\_\_\_ .  
 \_\_\_\_\_ .  
 \_\_\_\_\_ .  
 \_\_\_\_\_ .  
 \_\_\_\_\_ .  
 \_\_\_\_\_ .  
 \_\_\_\_\_ .  
 \_\_\_\_\_ .

\_\_\_\_\_ Date \_\_\_\_\_ .  
 Signature of submitter  
 \_\_\_\_\_  
 Title Company



## APPENDIX "C"

## MONTANA-DAKOTA UTILITIES CO.

## APPLICATION FOR INTERCONNECTION OF CUSTOMER-OWNED GENERATION

Who should file this application: Any customer interested in installing generation on their premises which will be interconnected with Company's electrical system. This application should be completed as early as possible and submitted to Company for processing.

This application is used by Company to perform a "Preliminary Interconnection Study" to determine the interface requirements at the point of interconnection with the Customer. Applicant should provide as much of the information requested on the form as possible.

## OWNER / APPLICANT INFORMATION:

Name: \_\_\_\_\_  
 Mailing Address: \_\_\_\_\_  
 City: \_\_\_\_\_ State: \_\_\_\_\_ Zip: \_\_\_\_\_  
 Phone Number: \_\_\_\_\_ Representative: \_\_\_\_\_

## PROJECT DESIGN / ENGINEERING (ARCHITECT) (as applicable):

Company: \_\_\_\_\_  
 Mailing Address: \_\_\_\_\_  
 City: \_\_\_\_\_ State: \_\_\_\_\_ Zip: \_\_\_\_\_  
 Phone Number: \_\_\_\_\_ Representative: \_\_\_\_\_

## ELECTRICAL CONTRACTOR (as applicable);

Company: \_\_\_\_\_  
 Mailing Address: \_\_\_\_\_  
 City: \_\_\_\_\_ State: \_\_\_\_\_ Zip: \_\_\_\_\_  
 Phone Number: \_\_\_\_\_ Representative: \_\_\_\_\_

## GENERATOR DATA:

Manufacturer (if available): \_\_\_\_\_ Model: \_\_\_\_\_  
 Type: Synchronous \_\_\_ Induction \_\_\_ Phases: Single \_\_\_ Three \_\_\_  
 Rated Output: \_\_\_\_\_ Kilowatt \_\_\_\_\_ Kilovolt-Ampere  
 Rated Power Factor (%): \_\_\_\_\_ Rated Voltage (Volts): \_\_\_\_\_  
 Rated Amperes: \_\_\_\_\_ Frequency (Hz): \_\_\_\_\_  
 Energy Source (Diesel, gas, steam, wind, etc.): \_\_\_\_\_



ESTIMATED LOAD INFORMATION:

The following information will be used to help properly design the Company-Customer interconnection. This information is not intended as a commitment or contract for billing purposes.

Minimum anticipated load (generation not operating) \_\_\_\_\_ (kW) \_\_\_\_\_ (kVA)

Maximum anticipated load (generation not operating) \_\_\_\_\_ (kW) \_\_\_\_\_ (kVA)

DESCRIPTION OF PROPOSED INSTALLATION AND OPERATION:

Attach a single line diagram showing the customer's primary switchgear, transformers and generation facilities. Give a general description of the manner of operation of the generation (co-generation, closed-transition peak shaving, open-transition peak shaving, emergency power, etc.).

Series of horizontal lines for handwritten input, each line ending with a period.

Applicant Signature \_\_\_\_\_ Date \_\_\_\_\_

Title \_\_\_\_\_ Company \_\_\_\_\_

INFORMATION BELOW TO BE COMPLETED BY Company:

Region/District: \_\_\_\_\_ Date \_\_\_\_\_ .  
Company Representative: \_\_\_\_\_ Phone: \_\_\_\_\_ .  
Name of Project: \_\_\_\_\_ .  
Street Address: \_\_\_\_\_ .  
City: \_\_\_\_\_ State: \_\_\_\_\_ Zip: \_\_\_\_\_ .  
Company service point location: \_\_\_\_\_ .  
\_\_\_\_\_ .

(attach service area map)

Copy of Application and Attachments To:

- Region Electric Superintendent
- Region Electric System Engineer
- Electric System Operations Manager - General Office
- Electric Distribution Manager - General Office
- Original to be retained by Company Representative named above.

Report of Tariff Schedule Change

NAME OF UTILITY: Montana-Dakota Utilities Co.  
 ADDRESS: 400 North Fourth Street  
 Bismarck, ND 58501

<u>Section No.</u>	<u>Class of Service</u>	<u>New Sheet No.</u>
1	Table of Contents	1.1
5	Guidelines for Interconnection Requirements and Parallel Operation of Customer Owned Generation Rate 137	18

Change: New tariff providing reference to Interconnection Guidelines.  
 (State part of tariff schedule affected by change, such as: Applicability, availability, rates, etc.)

Reason for Change Commission Order in EL06-018

Present Rates .....  
 Proposed Rates .....  
 Approximate annual reduction in revenue ..... N/A  
 Approximate annual increase in revenue ..... N/A

Points Affected	Estimated Number of Customers Whose Cost of Service will be:					
	Reduced		Increased		Unchanged	
	# of Customers	Amount in \$	# of Customers	Amount in \$	# of Customers	Amount in \$
All	N/A	N/A	N/A	N/A	N/A	N/A

Include Statement of Facts, expert opinions, documents and exhibits supporting the change requested.

Received: \_\_\_\_\_ Montana-Dakota Utilities Co. \_\_\_\_\_

By: \_\_\_\_\_  
 Executive Director  
 South Dakota  
 Public Utilities Commission

By: Donald R. Ball  
 Vice President - Regulatory Affairs

**On September 26, 2007 Montana-Dakota Utilities Co.,  
a Division of MDU Resources Group, Inc.,  
filed with the South Dakota Public Utilities Commission its  
Guidelines for Interconnection Requirements and Parallel  
Operation of Customer Owned Generation affecting  
entities considering interconnection with Montana-Dakota  
Utilities Co.'s electric system. The Interconnection  
Guidelines and South Dakota rules and regulations are  
available in this office for inspection. Please inquire at  
cashier's desk.**